

UPSTREAM - DOWNSTREAM

Fermentation technologies consist of two phases:

UPSTREAM-PROCESSING starts from the preparation of fermentation, runs through cell propagation and product formation until the „cut” of microbial process. At this point we have the ready fermentation broth containing the desired product. → previous lectures

DOWN-STREAM PROCESSING after the „cut” the product(s) will be isolated from the multicomponent broth and purified to marketable quality. → this lecture



WHAT IS COMMON IN DOWNSTREAM TECHNOLOGIES?

The product is in aqueous solution.

Multiphase system: water, +solid, +oily, (+air bubbles)

Complex system: many organic and inorganic substances, in solute, colloid and dispersed form

WHAT IS DIFFERENT?

Wide range in product concentration: 100 ppm → 10%-ig

Wide range in production scale: 100 g/year → 1.000.000 t/year

Many different operations (more than in chemical industry)



OPERATIONAL SEQUENCE

There are no fixed operational sequences but general guidelines:

1. Separation of cells → solid-liquid separation
other solids: medium pellets, CaCO_3 , product crystals

Typical operations:

Filtration

Centrifugation (settling)

(1/b Cell disruption: only with intracellular products)



BML Alkalmazott Biotechnológia és Élelmiszertudomány Tanszék

3

OPERATIONAL SEQUENCE

2. Concentration step(s) → components in large amount – like water – are to be separated.

Typical operations:

Extraction

Adsorption

Membrane filtration

Precipitation

(evaporation, distillation)



BML Alkalmazott Biotechnológia és Élelmiszertudomány Tanszék

4

OPERATIONAL SEQUENCE

3. Purification → separation of products and impurities.

Typical operations:

all previous
chromatography

4. Polishing → products are purified to achieve the demands of the market (standards, regulations, legal measures).

Typical operations:

all previous
crystallization
drying



PURIFICATION ↔ POLISHING

No strict distinction but different approach:

Purification: engineering approach, separation of impurities is optimized for minimal product loss.

Polishing: market approach, separation is optimized to fit the market demands even if a part of the product is lost.



LEVELS OF PURITY

- Human injection pharma products
- Human enteral pharma products
- Veterinary pharma products
- Food
- External pharma products
- Cosmetics (short → long contact)
- Technical – raw material for other products

The Pharmacopoeia quality is not always the best! (e.g. NaCl in dextrose.)



CELL DISRUPTION

Reference: There are no fixed operational sequences but general guide-lines:

(1/b Cell disruption: only with intracellular products)

How strong is the cell wall?

Animal cells burst in deionized water, the microorganisms do not – the cell wall resists the osmotic pressure.

How large is this pressure?

Physiological saline solution = 0,9% NaCl → $\sim 1/6$ Mol → $\sim 1/3$ osmol → $p \sim 24/3 = 8$ bar → pressure vessel



KINETICS OF CELL DISRUPTION

The outflow of inner product (P_i) can be described with a first order kinetic equation – it's independent from disruption method:

$$\frac{dP_i}{dt} = -kP_i$$

$$\int_{P_{i0}}^{P_i} \frac{dP_i}{P_i} = - \int_0^t k dt$$

Separation and integration of the equation gives an exponential form:

$$P_i = P_{i0} \cdot e^{-kt}$$

It is more practical to calculate the recovered product (R):

$$R = P_{i0} - P_i$$



BML Alkalmazott Biotechnológia és Élelmiszertudomány Tanszék

9

KINETICS OF CELL DISRUPTION

The amount of recovered product is:

$$R = P_{i0} [1 - e^{-kt}]$$

The sensitive product molecules can simultaneously decompose or denature. This process also can be described with a first order kinetic :

$$\frac{dS}{dt} = -K_d S$$

where:

S – specific activity of product

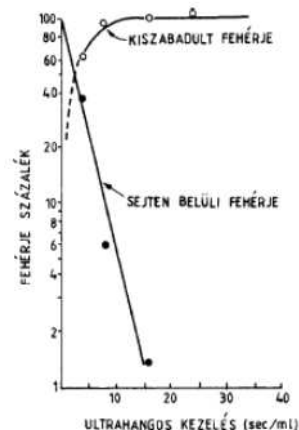

BML Alkalmazott Biotechnológia és Élelmiszertudomány Tanszék

10

KINETICS OF CELL DISRUPTION

Specific activity decreases exponentially with time:

$$S = S_0 e^{-K_d t}$$

The resultant yield is the product of the two parameters:

$$R_e = RS$$

Substituting the forms:

$$R_e = P_{i0} [1 - e^{-kt}] [S_0 e^{-K_d t}]$$

Contracting the constants:

$$R_e = K(1 - e^{-kt}) e^{-K_d t}$$



KINETICS OF CELL DISRUPTION

There is an optimal process time when the resultant yield is maximal.

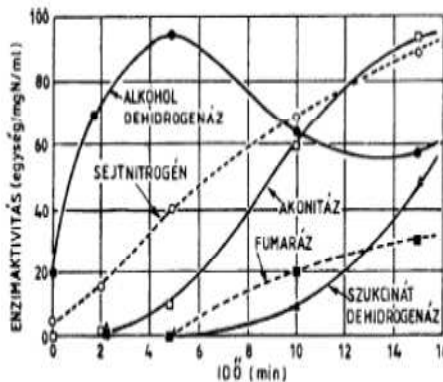
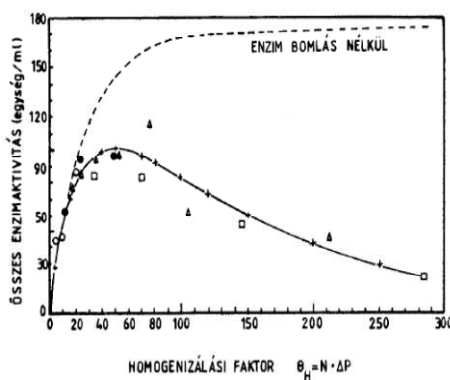

CELL DISRUPTION WITH ULTRASOUND

„Sonication”
 15-25 kHz
 Cavitation mechanism
 Heat dissipation → cooling
 Free radicals

Labor size only.



SONOPULS HD 2070



BMTL Alkalmazott Biotechnológia és Élelmiszertudomány Tanszék

13

BEAD MILLS

Pigment homogenisator
 from paint industry.

0,1-2 mm abrasion-resis-
 tant glass beads

rubbing-abrading effect

Agitator discs

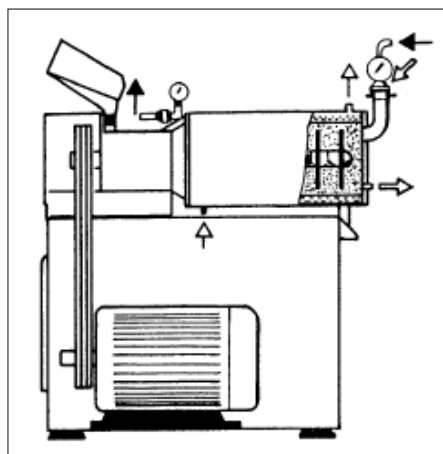

BMTL Alkalmazott Biotechnológia és Élelmiszertudomány Tanszék

14

BEAD MILLS

Advantages:

- continuous operation possible
- scale up possible

Disadvantages:

- Large energy consumption (needs cooling)



BML Alkalmazott Biotechnológia és Élelmiszertudomány Tanszék

15

HIGH PRESSURE HOMOGENISATORS

Cell suspension is pressed through a special orifice (homogenizing valve) with extreme high pressure (200 - 600 - 1000 bar).
In dairy → homogenized milk.

Disruption mechanisms:

- Flow shear
- Collision

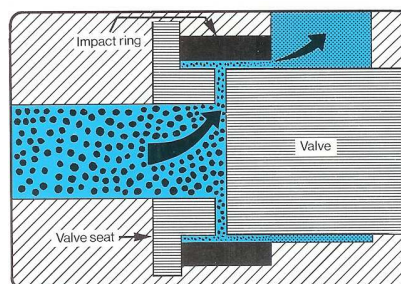
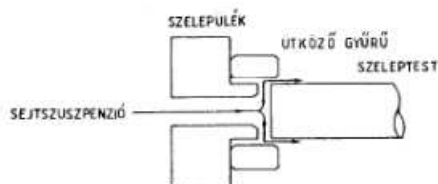

BML Alkalmazott Biotechnológia és Élelmiszertudomány Tanszék

16

HIGH PRESSURE HOMOGENISATORS

Continuous disruption: regulated (spring) valves

Single stage (200 – 600 bar) and

Double (600 -1000 bar) valves

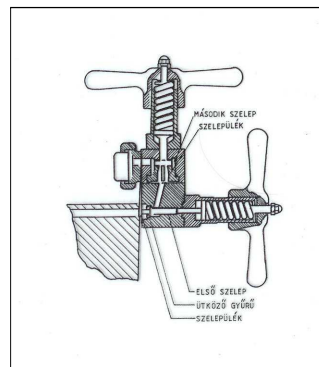
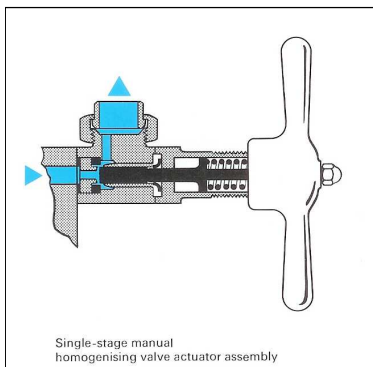

BME Alkalmazott Biotechnológia és Élelmiszertudomány Tanszék

17

HIGH PRESSURE HOMOGENISATORS

Advantages:

- Possible continuous operation
- Possible scale up

Disadvantages:

- Robust construction
- Danger of clogging

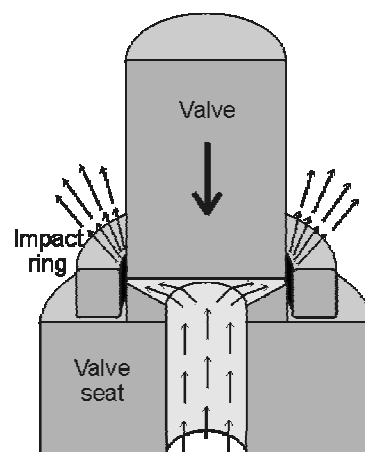

BME Alkalmazott Biotechnológia és Élelmiszertudomány Tanszék

18

X-PRESS

Frozen cell suspension is pressed through an orifice.

How is it possible?

If the pressure is high enough → 2000 – 6000 bar → the ice gets compressible = deformable.

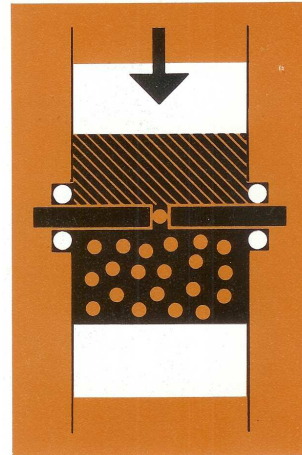

BME Alkalmazott Biotechnológia és Élelmiszertudomány Tanszék

19

PHASE DIAGRAM OF ICE

The first triple point:
-22 °C, 211,5 MPa

Relative density of crystal forms:
Ice-1 → 0,92
vol reduction: -19%
Ice-3 → 1,14
vol reduction : -7%
Ice-5 → 1,23

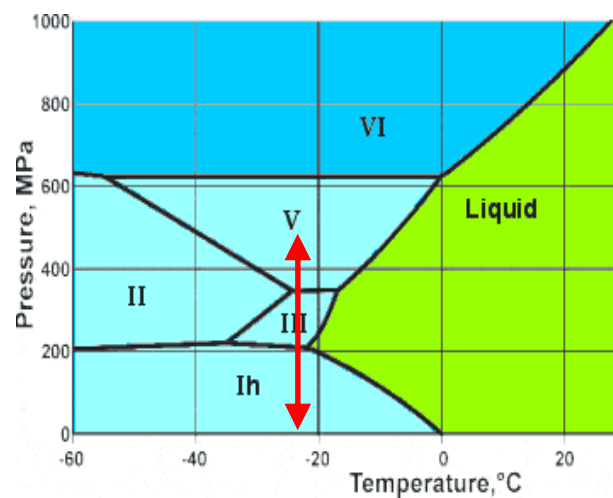

BME Alkalmazott Biotechnológia és Élelmiszertudomány Tanszék

20

X-PRESS

Advantages:

- High efficiency
- No denaturation, decay
- Very concentrated cell cake can be disrupted

Disadvantages:

- Batch operation only
- No scale up
- Heavy construction

X-PRESS Zellendesintegrator

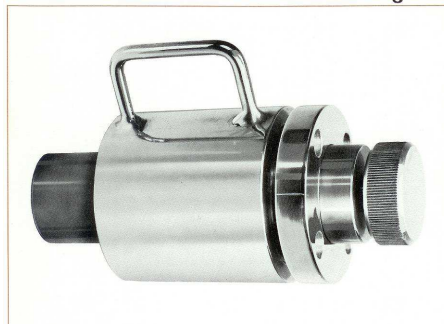

PHYSICAL METHODS

Drying:

- Hot air drying is slow and denaturing. But:
- Freeze drying (lyophilization) (no denaturation)
- Solvent drying (acetone powder)
(combination with ether)

Freezing – melting

Heat shock – in aqueous medium



PHYSICAL METHODS

Osmotic shock: with neutral compounds (sugars, sugar alcohols, glycerol), not with salts

Solvent treatment:

- drying with acetone than ether
- Autolysis of yeasts with toluene

Detergent treatment:

They penetrate into the cell membrane and destroy its structure.

- Both cationic and anionic
- Bile acids



PHYSICAL METHODS

Decompression

Henry's law:

$$C^* = \frac{1}{H(t)} \cdot P_i$$

At high pressure a lot of gas is dissolved in the liquid (even inside the cells).

With a sudden pressure drop the solubility drops, too - the gas forms bubbles everywhere (like in sodas)



ENZYMATIC METHODS

Specific enzymes hydrolyzing the cell wall:

- | | |
|-------------|--|
| bacteria | - lysozyme |
| yeasts | - mannanase (Yeast Lyase, <i>Cytophaga sp.</i>) |
| moulds | - chitinase, cellulase |
| plant cells | - cellulase |

Multicomponent preparates:

- | | |
|--|-----------------|
| snail enzyme | - gastric juice |
| induced enzymes of <i>Trichoderma sp</i> | |

