

BMEVESAA604 2022.03.01.
Analitikai és Szerkezetvizsgáló labor
Tömegspektrometria

Tömegspektrometria (MS)

Mátyási Judit, Dr. Balla József

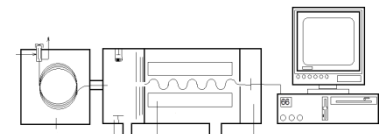

Követelmények

Laborjegy:

beugró zh, jegyzőkönyv minősége alapján +/- 1 jegy

Beugró zh:

MS előadás anyaga (a diasor plusz az elhangzottak!)

Diasor:

http://oktatas.ch.bme.hu/oktatas/konyvek/anal/BSc-Analitikai-es-Szerkezetvizsgalati-Szaklabor/MS_bevezeto_2022tavasz.ppt

Helyszín:

Ch. ép. fsz. 3.

A tömegspektrometria definíciója:

1. Dinamikus **tömegmérési** módszer
2. Csökkentett nyomású térben gerjesztés hatására a mintából keletkező ionokat gyorsító elektrosztatikus tér hatására olyan erőterbe juttatjuk, ahol fajlagos tömegük (m/z) szerint elkülönülnek, és ezt követően egy detektorban mérjük az ionok intenzitását. Az ionintenzitás-fajlagos tömeg közötti függvénykapcsolat a **tömegspektrum**. A tömegspektrum egyedi. **(Ujjlenyomat.)**



Tömegspektrum:

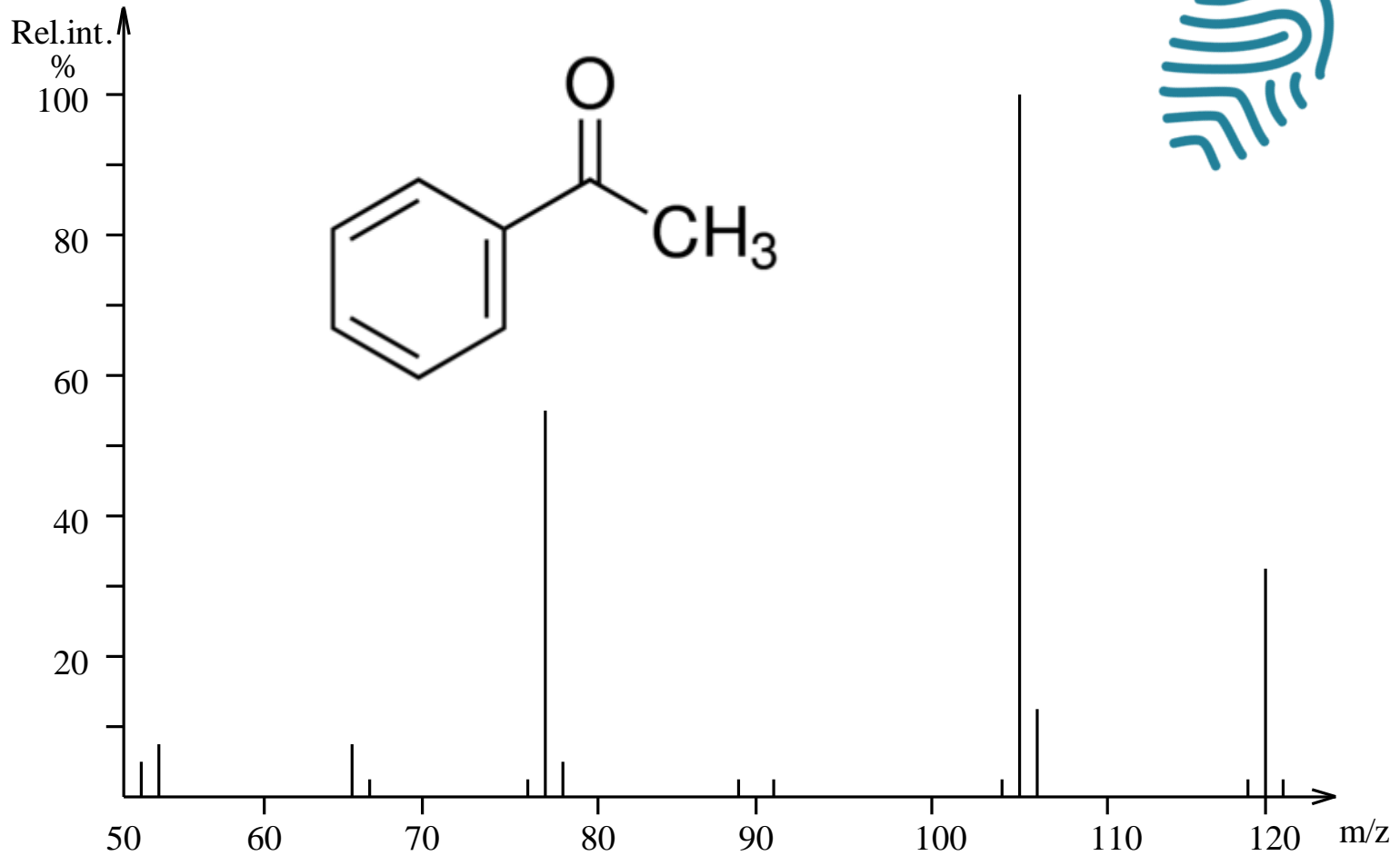

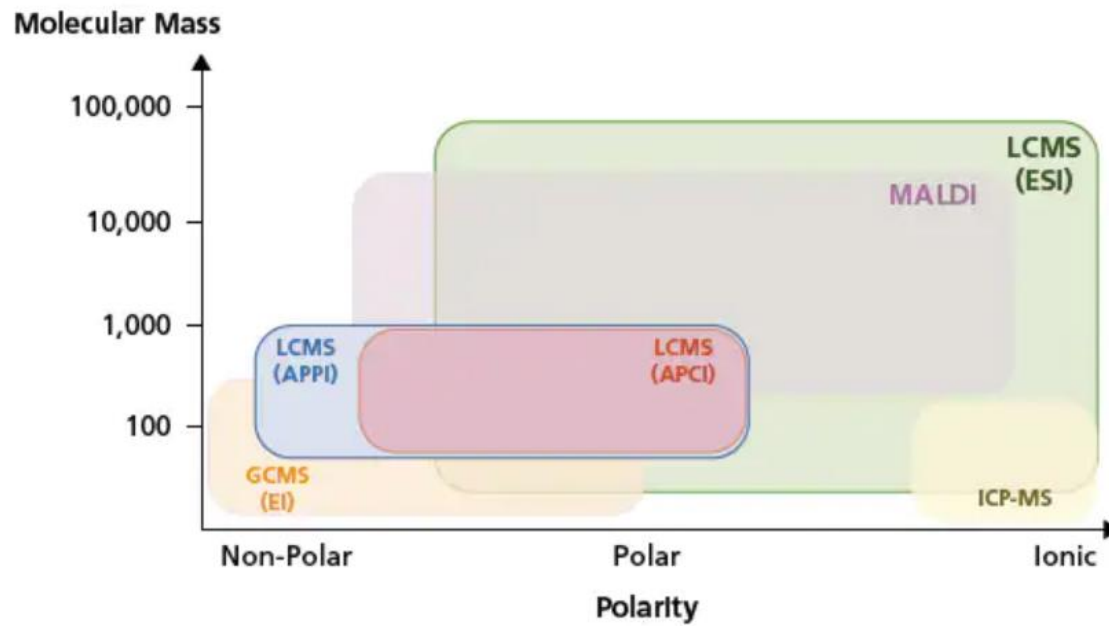

GC-MS-DS

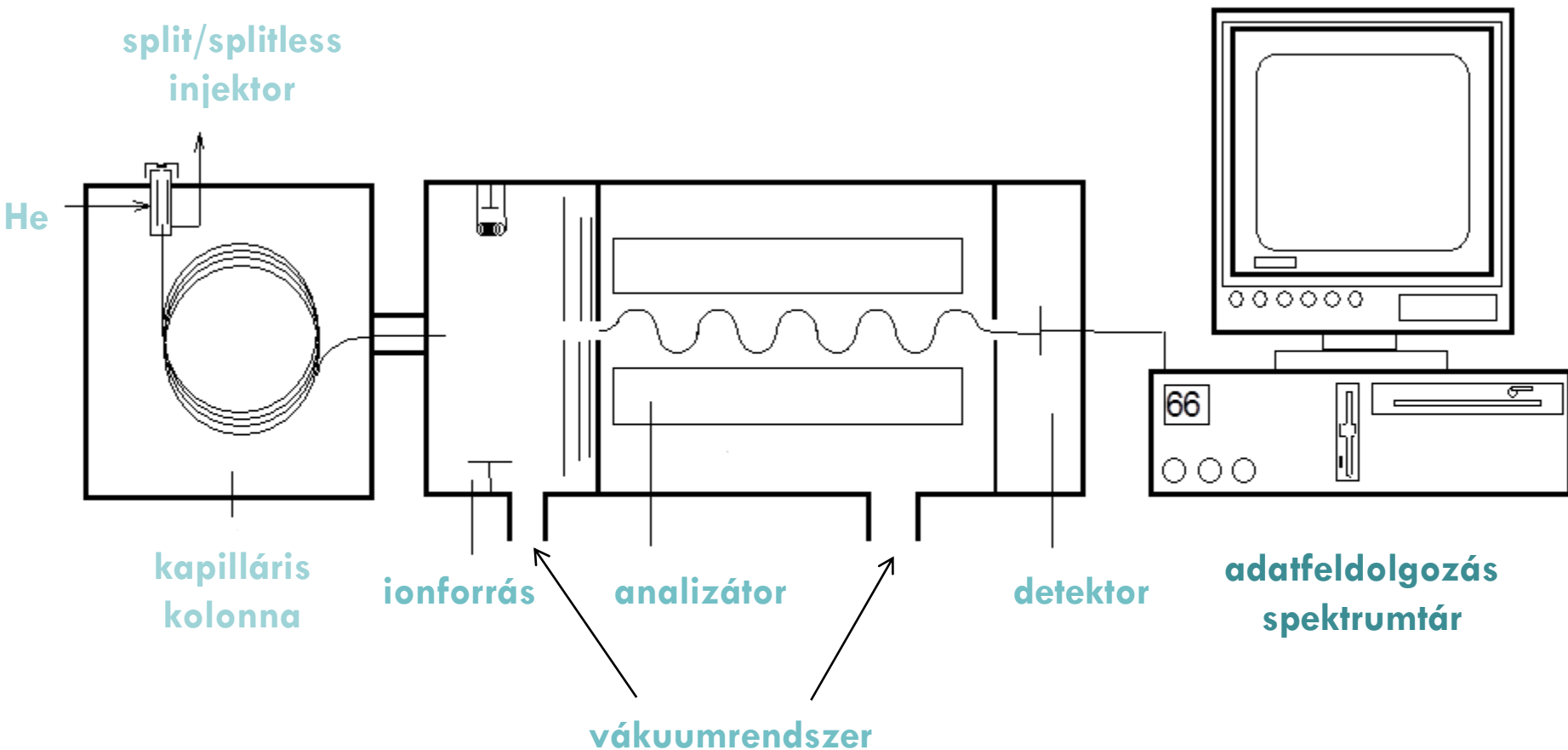

GC

MS

DS

Forrpont és gázkromatografálhatóság

Injektor hőmérsékletén bomlás nélkül elpárologtatható komponensek

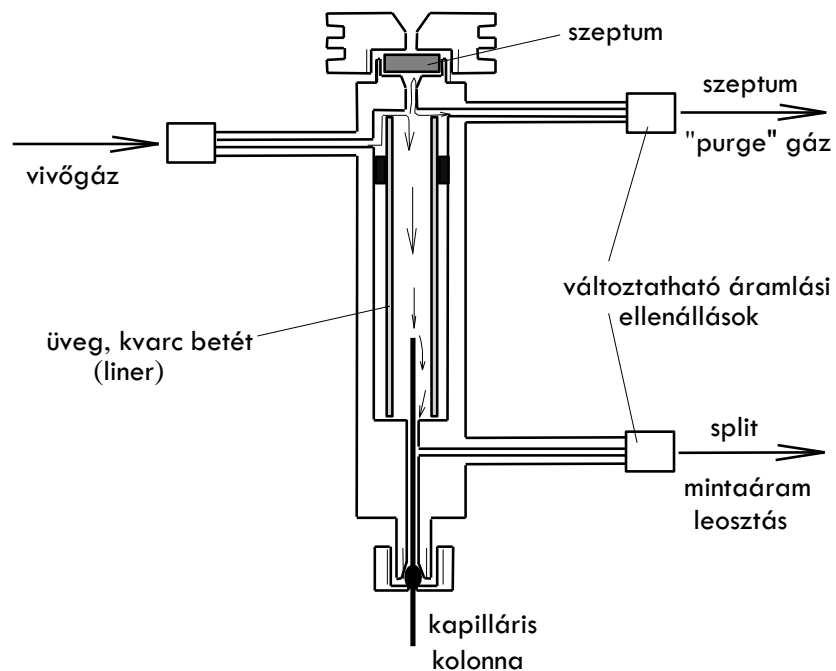

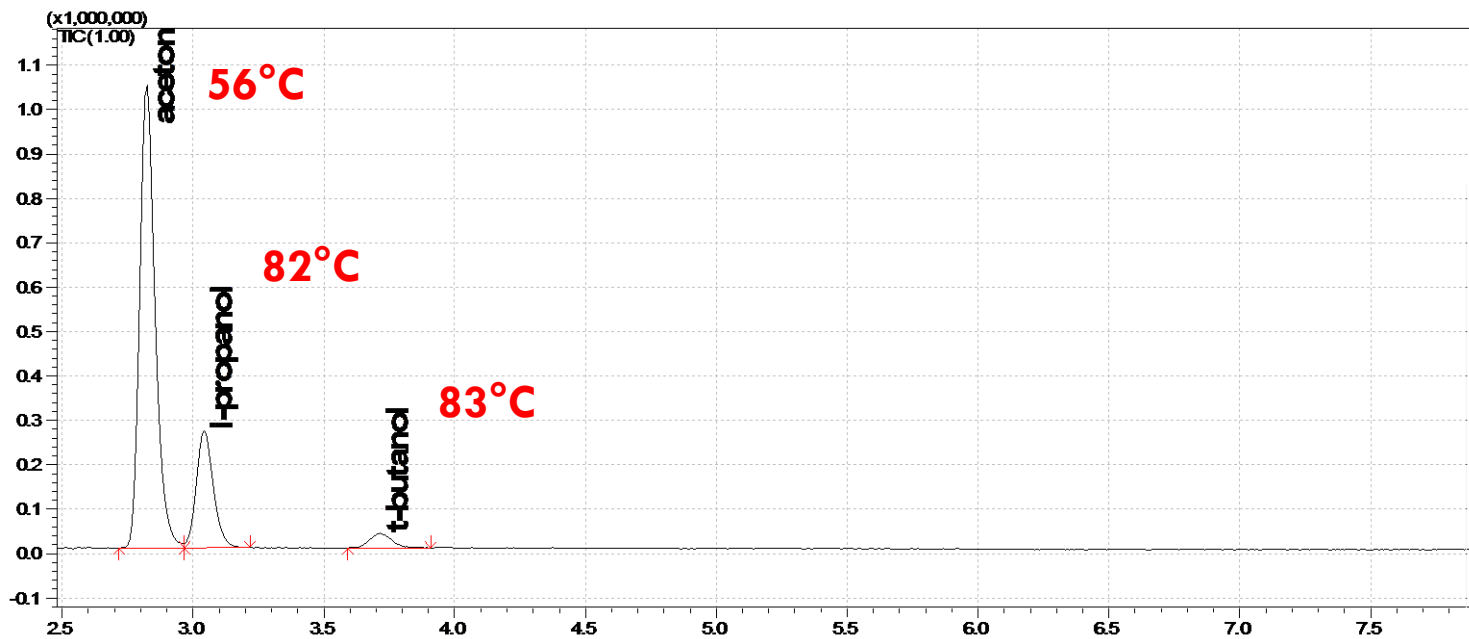

Technológiai oldószermaradványok vizsgálata

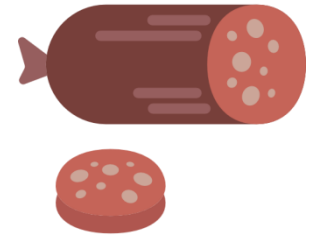

PAHs	Chemical formula	Molecular weight (g/mol)	CAS number	Ring number	Melting point (°C)	Boiling point (°C)
Naphthalene	C ₁₀ H ₈	128	91-20-3	2	80.2	218
Acenaphthylene	C ₁₂ H ₈	152	208-96-8	3	92.5	280
Acenaphthene	C ₁₂ H ₁₀	152	83-32-9	3	93.4	279
Fluorene	C ₁₃ H ₁₀	166	86-73-7	3	115	295
Phenanthrene	C ₁₄ H ₁₀	178	85-01-8	3	99.2	340
Anthracene	C ₁₄ H ₁₀	178	120-12-7	3	215	340
Fluoranthene	C ₁₆ H ₁₀	202	206-44-0	4	108	384
Pyrene	C ₁₆ H ₁₀	202	129-00-0	4	151	404
Benzo[a]anthracene	C₁₈H₁₂	228	56-55-3	4	167	435
Chrysene	C ₁₈ H ₁₂	228	218-01-9	4	258	448
Benzo[b]fluoranthene	C ₂₀ H ₁₂	252	205-99-2	5	168	481
Benzo[k]fluoranthene	C ₂₀ H ₁₂	252	207-08-9	5	217	480
Benzo[a]pyrene	C ₂₀ H ₁₂	252	50-32-8	5	177	495
Dibenzo[a,h]anthracene	C ₂₂ H ₁₄	278	53-70-3	5	270	524
Indeno[1,2,3-cd]pyrene	C ₂₂ H ₁₂	276	193-39-5	6	164	536
Benzo[g,h,i]perylene	C ₂₂ H ₁₂	276	191-24-2	6	278	550

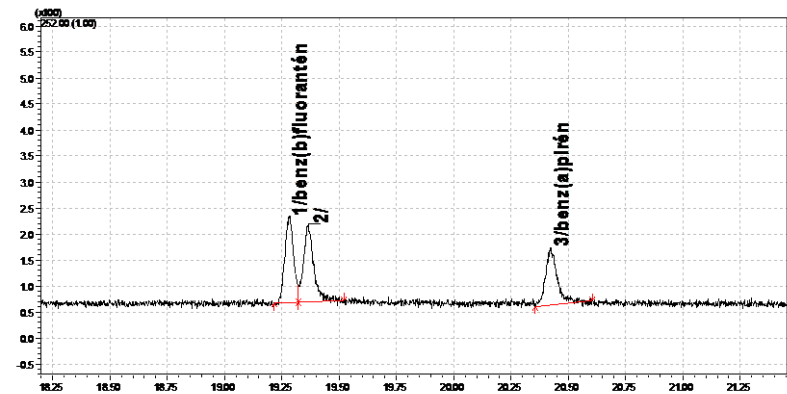
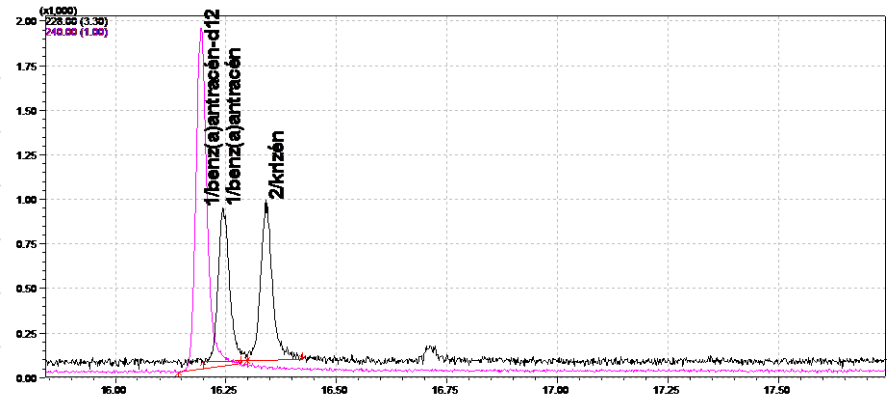

Gázelemzések

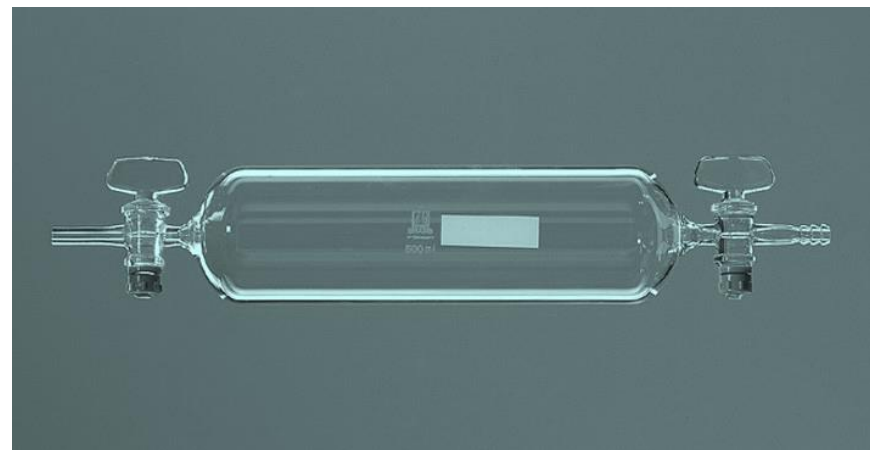
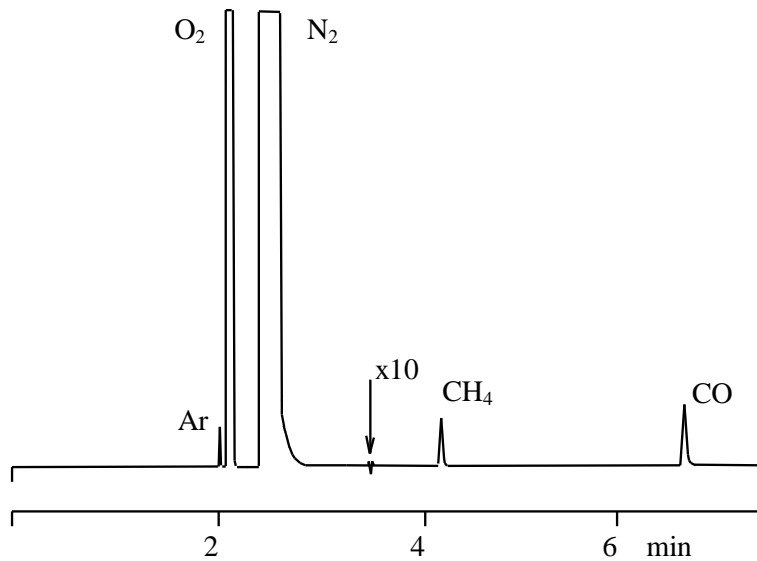

GC-MS-DS

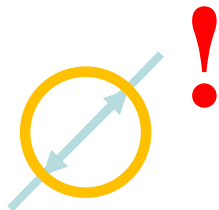

split/splitless
injektor

He

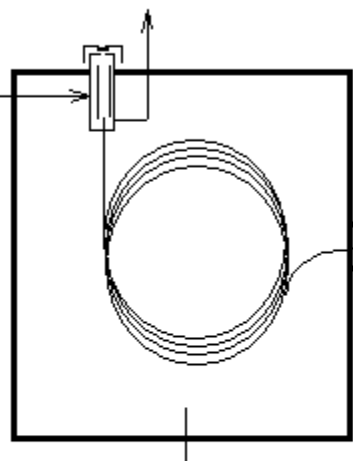

kapilláris
kolonna

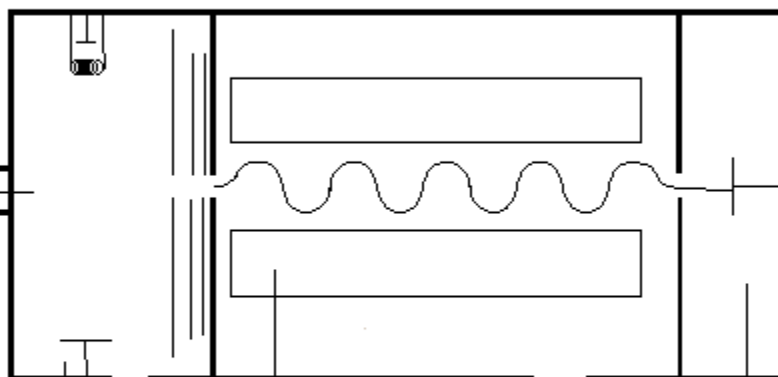

ionforrás

analizátor

detektor

vákuumrendszer

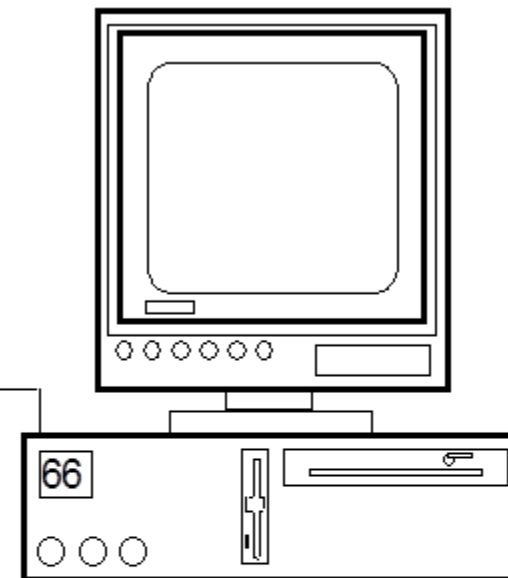

adattfeldolgozás
spektrumtár

GC

MS

DS

GC-MS-DS

Automata

- folyadék
- HS analízis
- SPME
- ITEX



Automata mintaadagoló

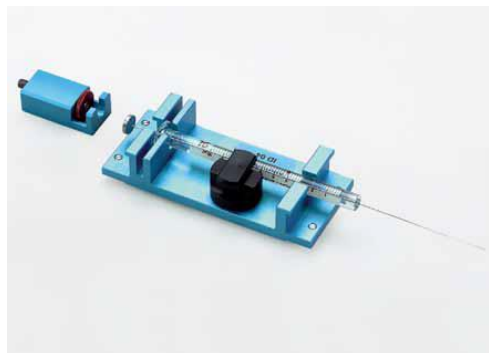

GC-MS/MS-DS



Direkt mintabevitel



A tömegspektrométer egységei

1. Ionforrás:

1. EI (Electron Impact, elektronütközéses)
2. CI (Chemical Ionization, kémiai ionizációs)

2. Analizátor

1. Elektromos
 1. Kvadrupól
 2. Ioncsapda
2. Kettős fókuszálású (mágneses+elektrosztatikus)
3. TOF (time of flight, repülési idő)
4. Orbitrap

3. Detektor

1. Elektronsokszorozó
2. Fotoelektronsokszorozó

Ionforrás

Elektronütközéses (EI, Electron Impact)

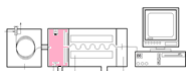
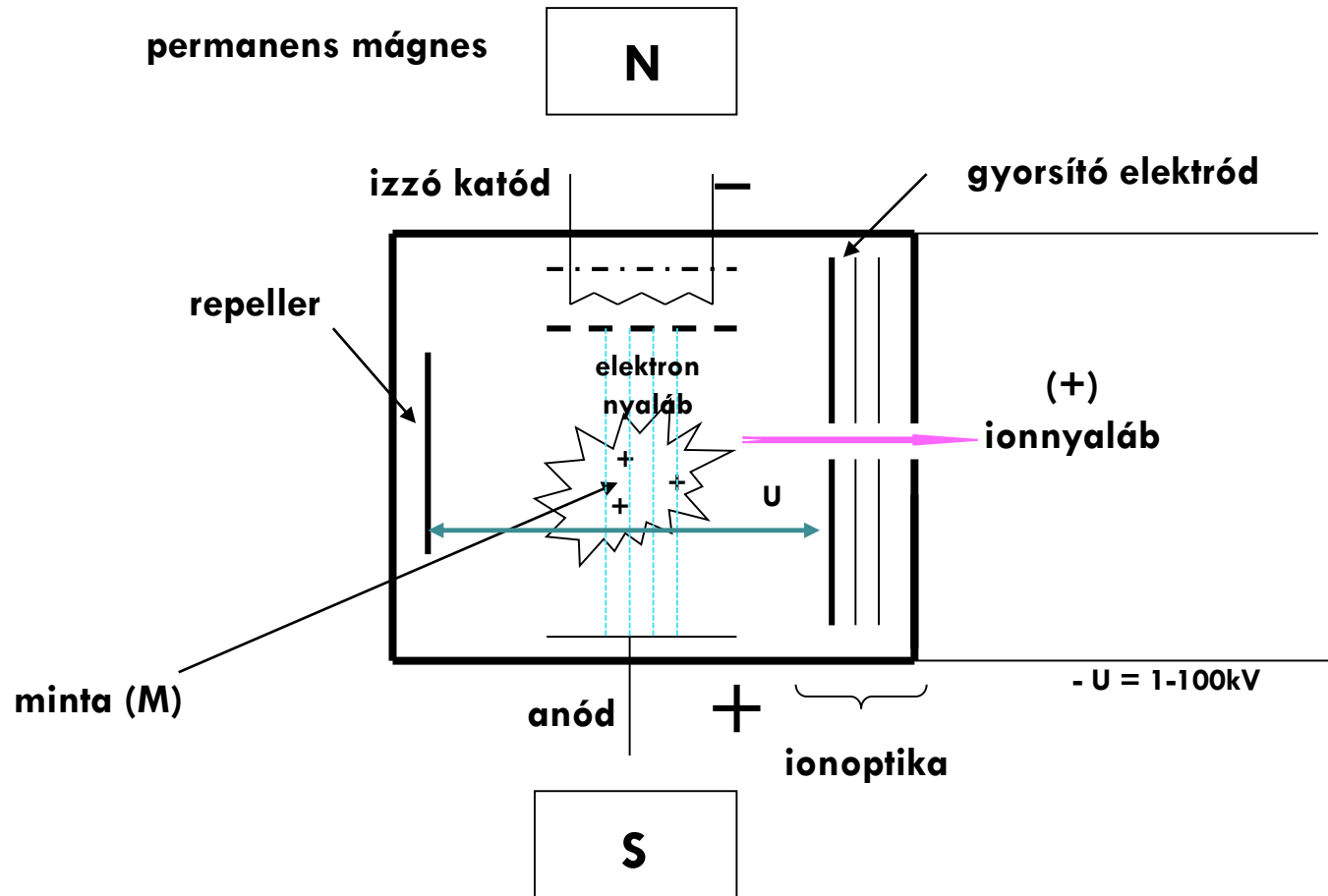

Ionforrás

Elektronütközéses (EI, Electron Impact)

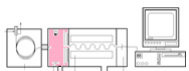

Ionforrás

Elektronütközéses (EI, Electron Impact)

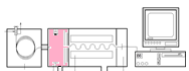
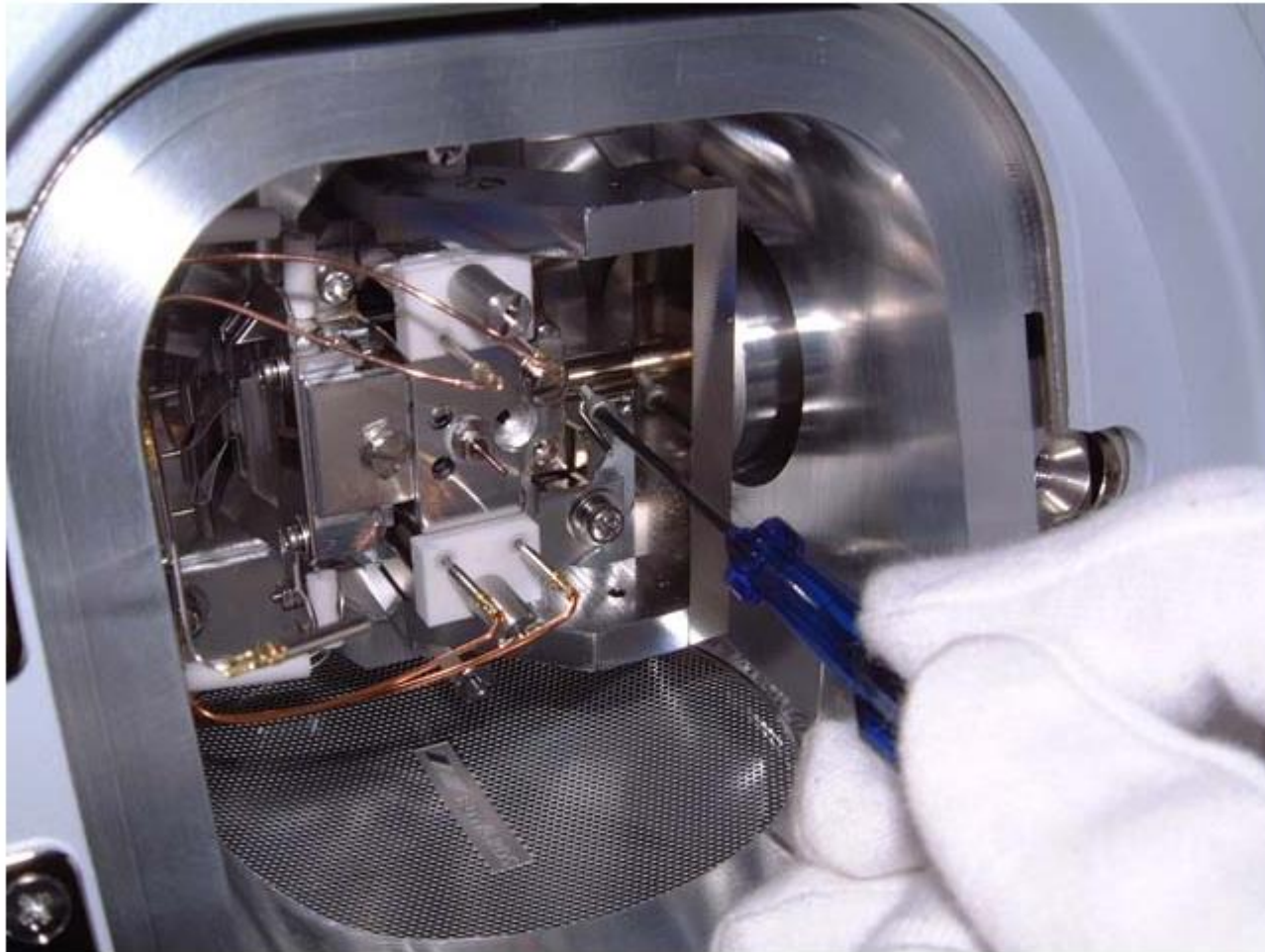

Ionforrás

Elektronütközéses (EI, Electron Impact)

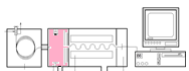
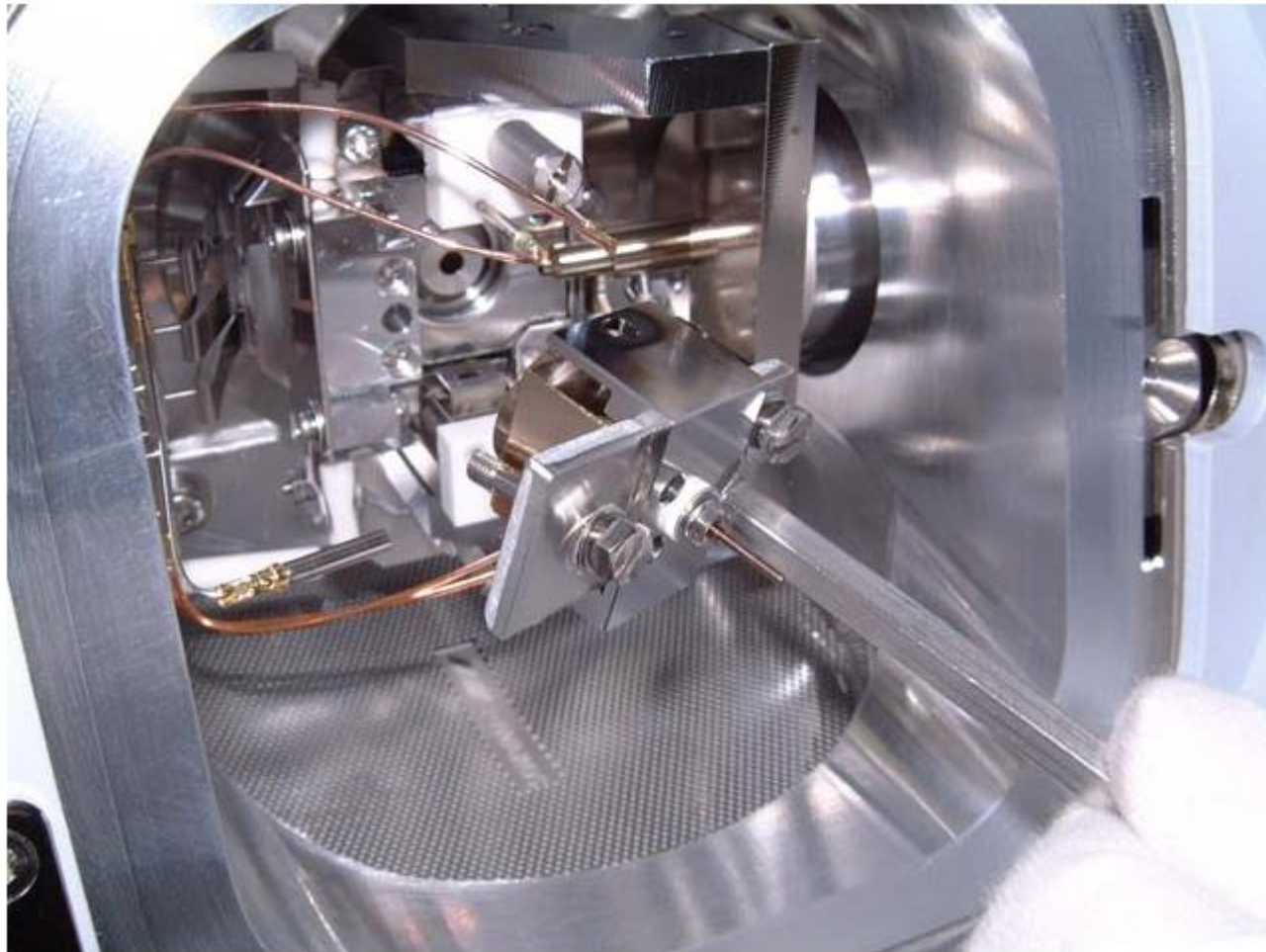

Ionforrás

Elektronütközéses (EI, Electron Impact)

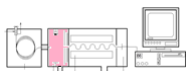
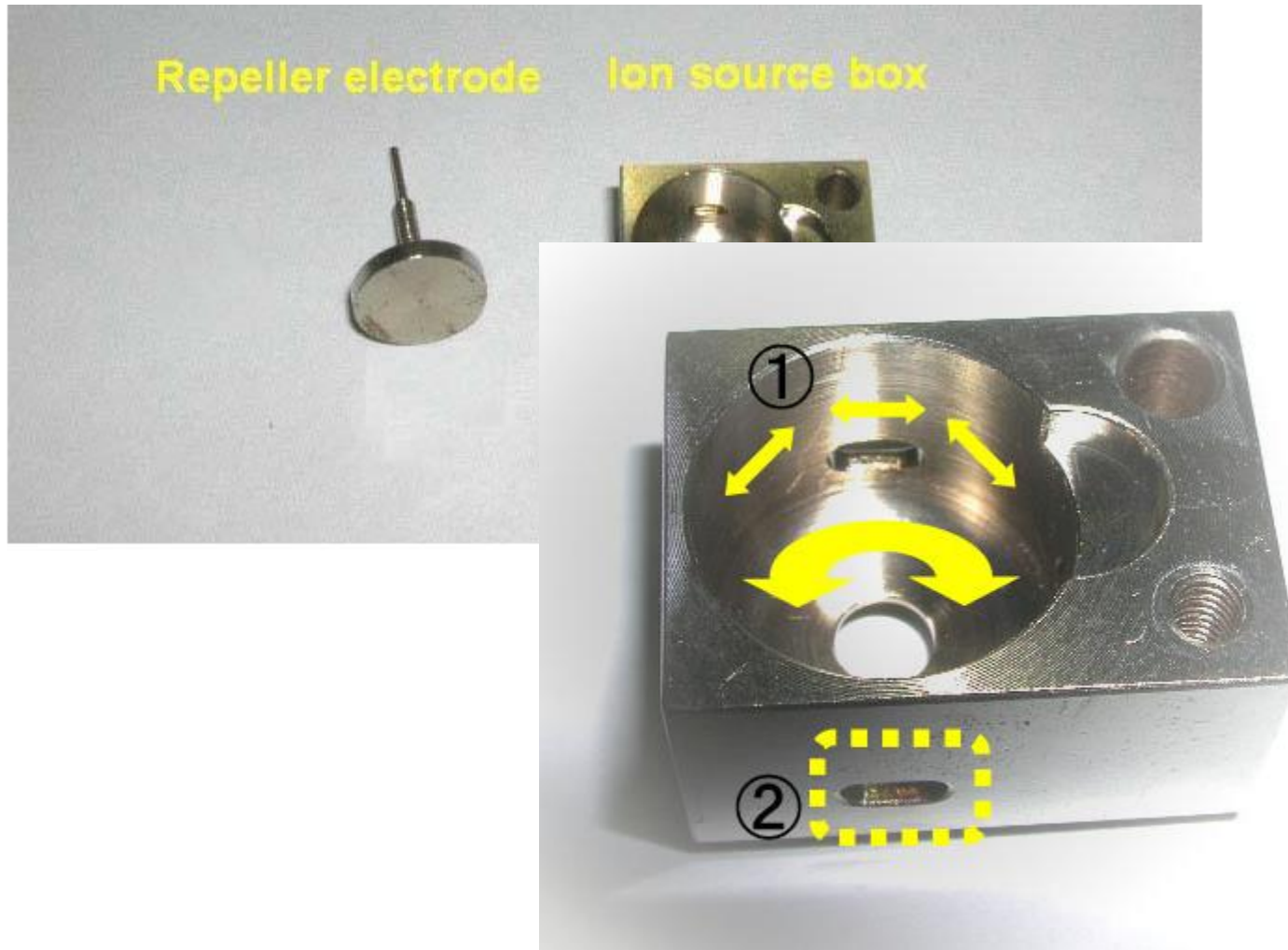

Ionkémiai folyamatok

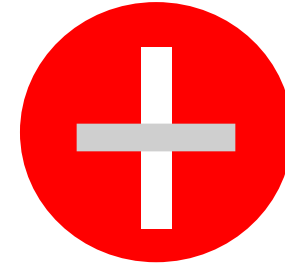

1. A molekula ionizációja

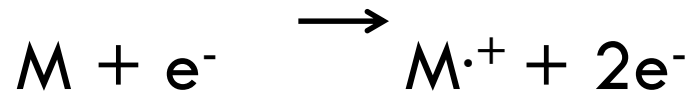

2. Hasadás és/vagy átrendeződés

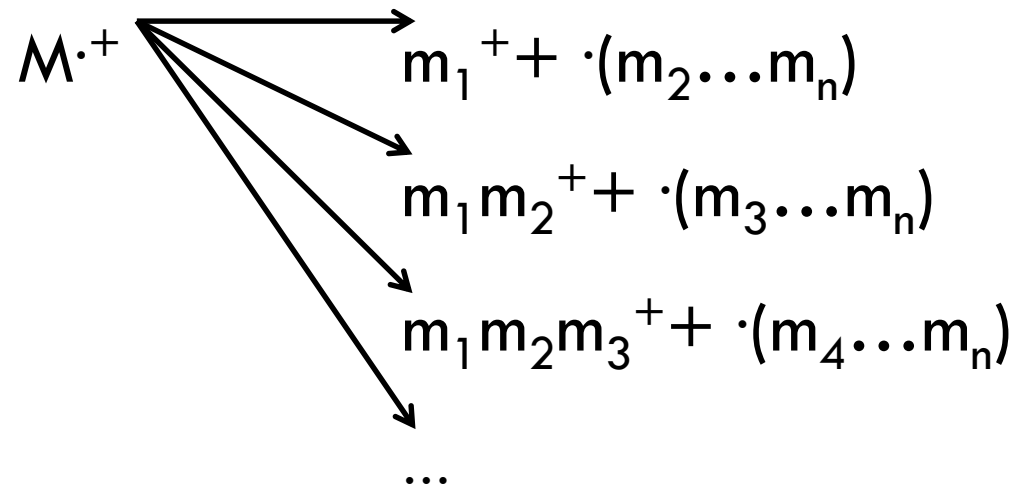

A molekulaion szimultán, monomolekuláris fragmentálódási reakciókban vesz részt, melyek mindig ugyanakkora valószínűséggel, aránnyal játszódnak le.



Miért pont 70 eV?

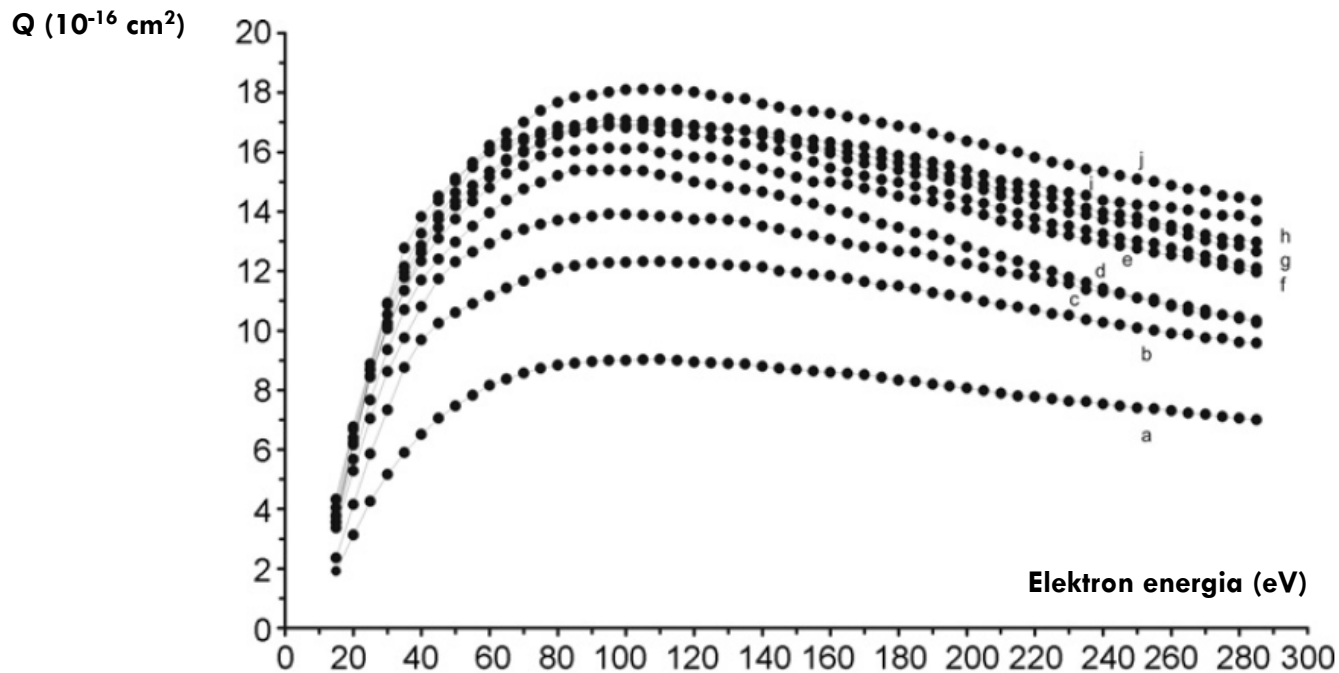

Néhány C_2 - C_6 közötti szénatomszámú, oxigéntartalmú szerves vegyület elektronütkezési hatáskeresztmetszet (Q) görbéje

J. N. Bull, P. W. Harland, Absolute electron impact ionization cross-sections and polarisability volumes for C2 to C4 aldehydes, C4 and C6 symmetric ethers and C3 to C6 ketones, *Int J Mass Spec*, 273, (1–2), 2008, p. 53–57



Az ionizáló feszültség hatása a fragmetációra

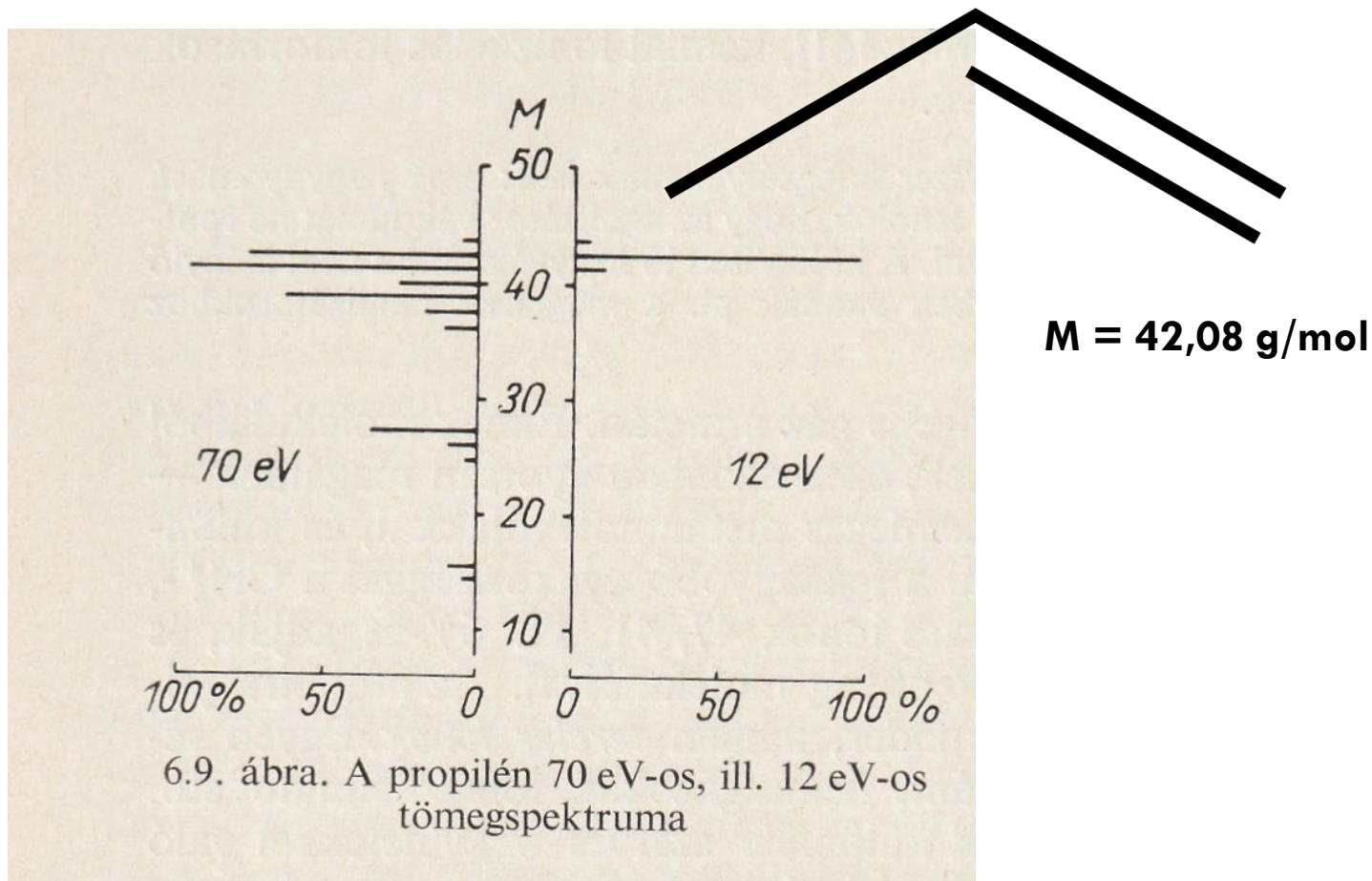

He és a 70 eV

Néhány vegyület első ionizációs potenciálja

vegyület	eV	vegyület	eV	vegyület	eV
nitrogén	15,58	kloroform	11,42	kén-dioxid	12,34
oxigén	12,08	1,2-diklór-etán	11,12	kén-hidrogén	10,46
víz	12,59	vinil-klorid	10	karbonil-szulfid	11,18
szén-monoxid	14,01	diklór-etilén	9,83	szén-diszulfid	10,08
szén-dioxid	13,79	triklór-etilén	9,45	tiokarbinol	9,44
nitrogén-oxid	9,25	fenol	8,5	dimetil-szulfid	8,69
nitrogén-dioxid	9,78	piridin	9,32	dimetil-diszulfán	8,46
klór	11,48	benzol	9,25	formaldehid	10,87
jód	9,28	toluol	8,82	acetaldehid	10,21
metán	12,98	xilol	8,45	akrolein	10,1
etilén	10,52	sztirol	8,47	aceton	6,69
acetilén	11,41	anilin	7,7	metanol	10,85
butén-1	9,58	ammónia	10,15	etanol	10,48
n-hexán	10,17	metil-amin	9,97	hangyasav	11,05
metil-klorid	11,28	acetonitril	12,22	ecetsav	10,37
széntetraklorid	11,47	akril-nitril	10,91	He	24

- A He is ionizálódik 70 eV mellett, csak viszonylag kis mértékben a nagy IE miatt
- 4 m/z nem zavar a spektrumban



Ionforrás

Kémiai ionizációs (CI, Chemical Ionization)

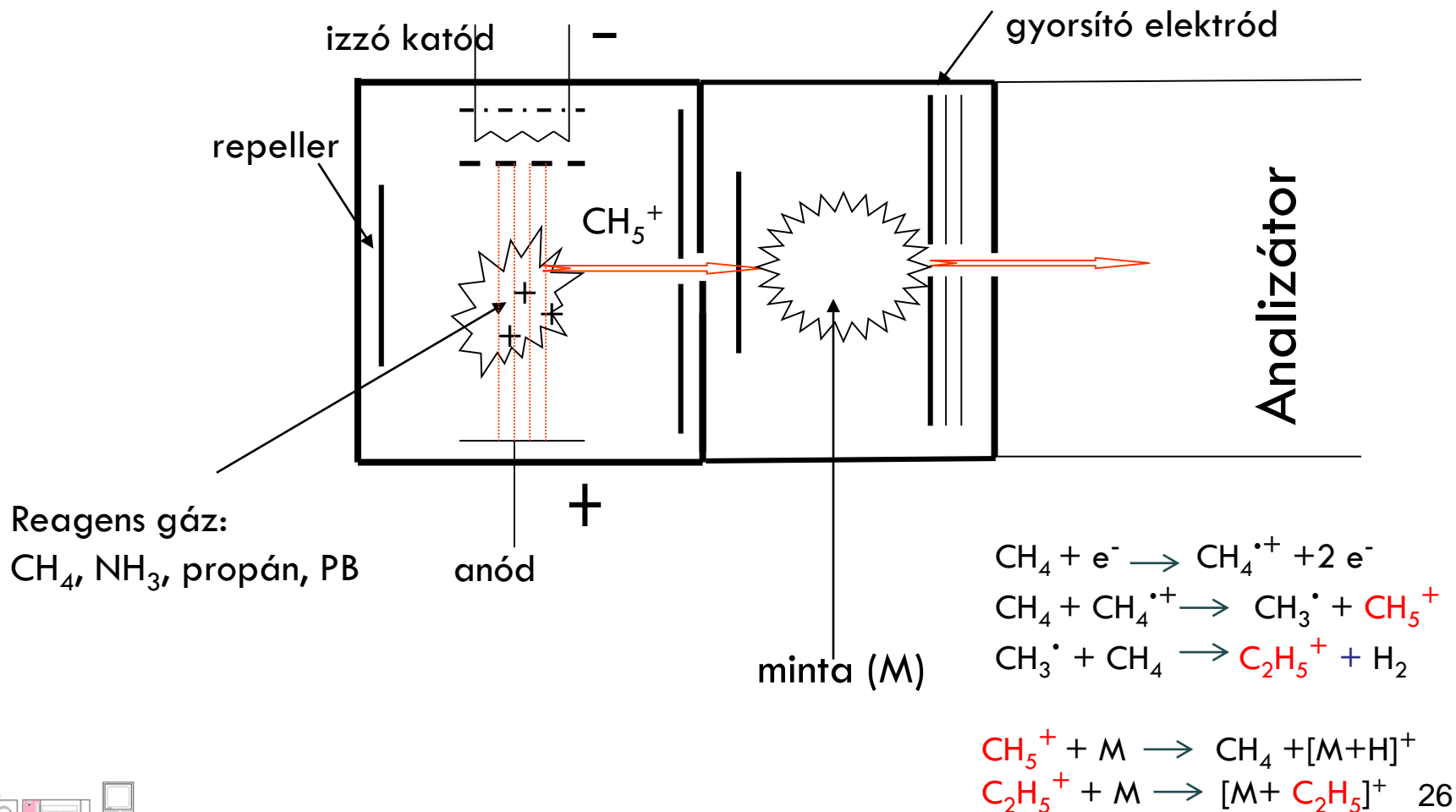

EI és CI ionforrásból származó tömegspektrumok

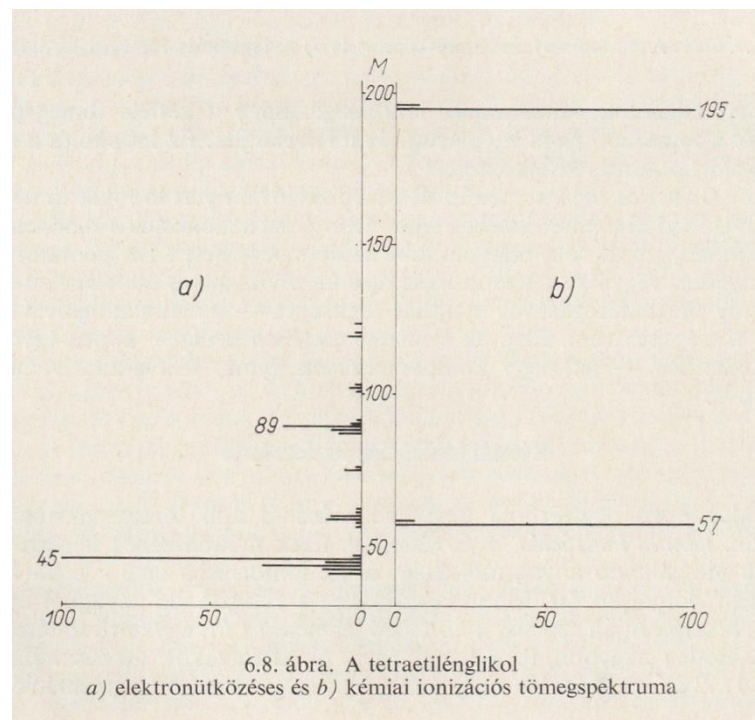
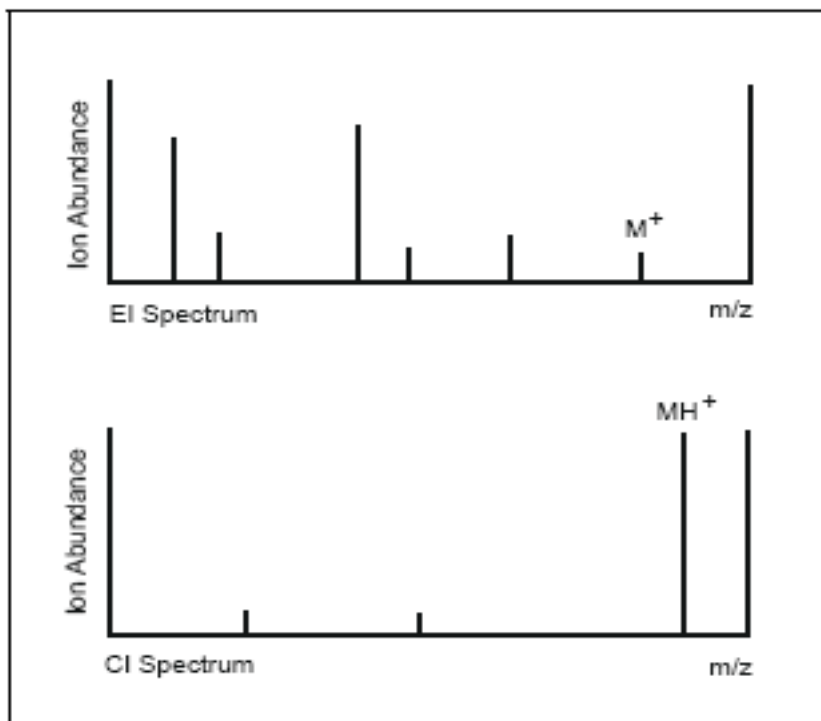
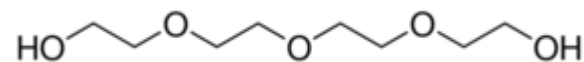

Comparison of EI and CI mass spectra illustrating the greater degree of fragmentation in the former and the greater abundance of quasimolecular ions in the latter.

M = 194,23 g/mol



Analizátor Kvadrupól

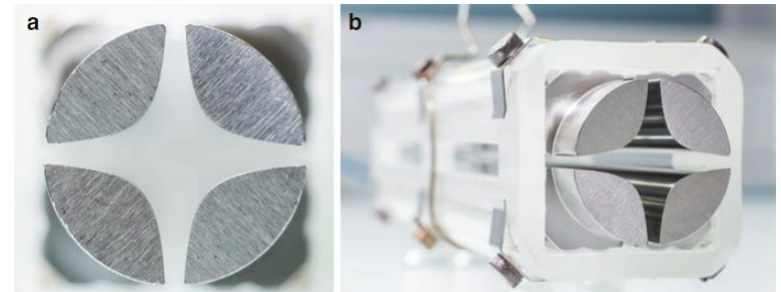
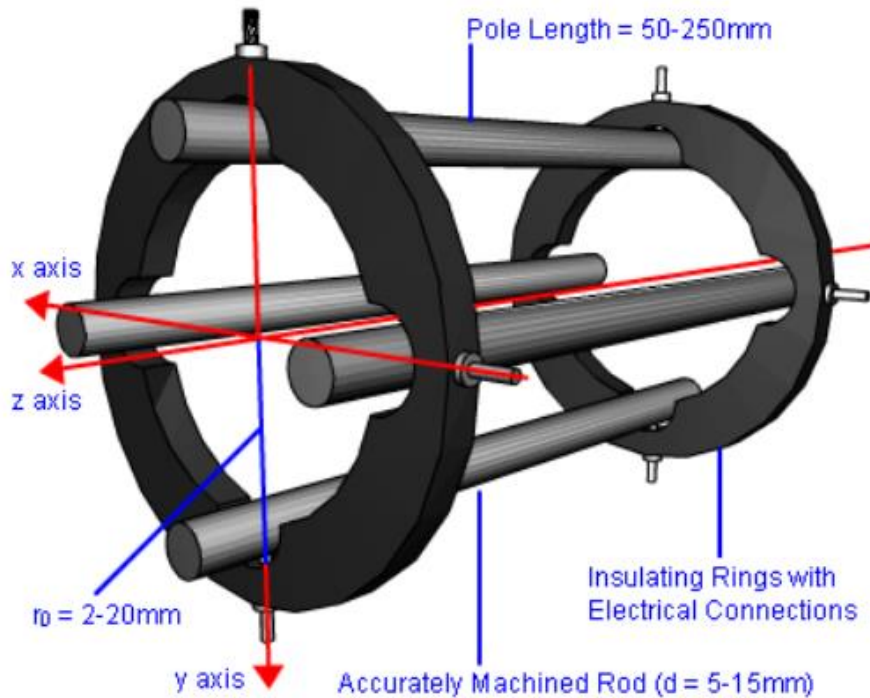

Mass Spectrometry, 2017, Jürgen H. Gross

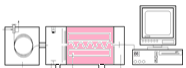

Analizátor Kvadrupól

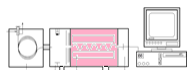
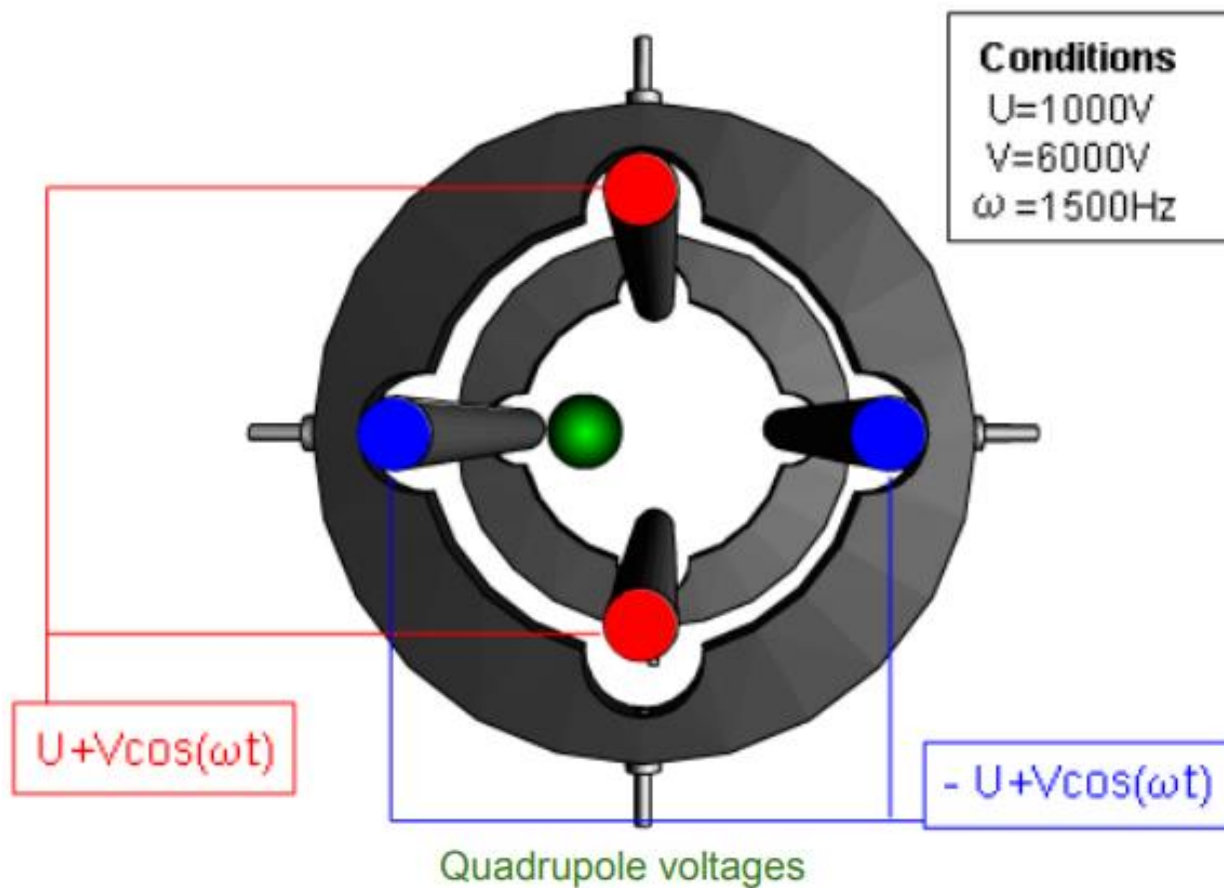

Analizátor Kvadrupól

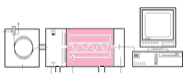
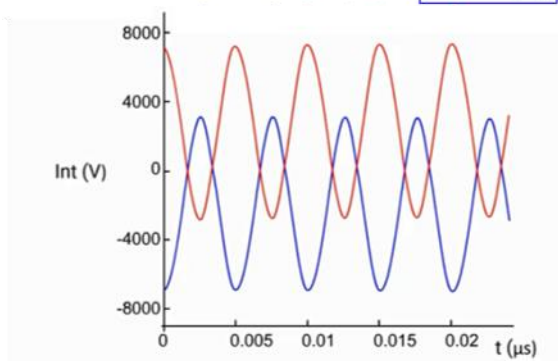
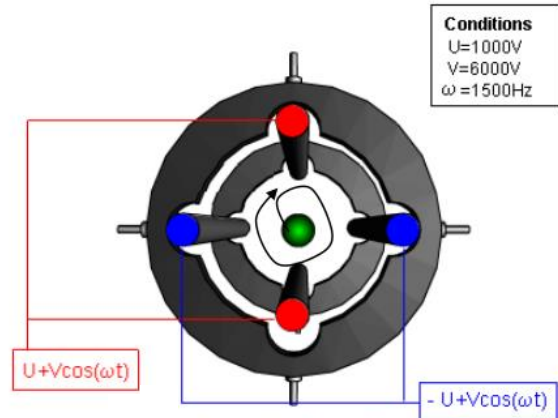
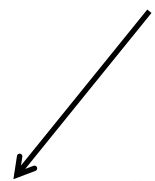
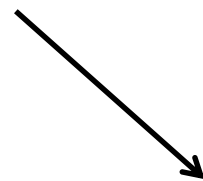
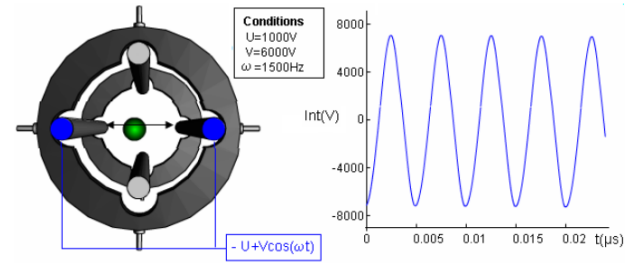
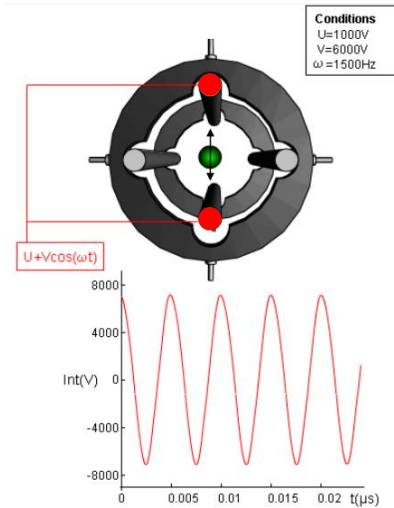

Analizátor: kvadrupól

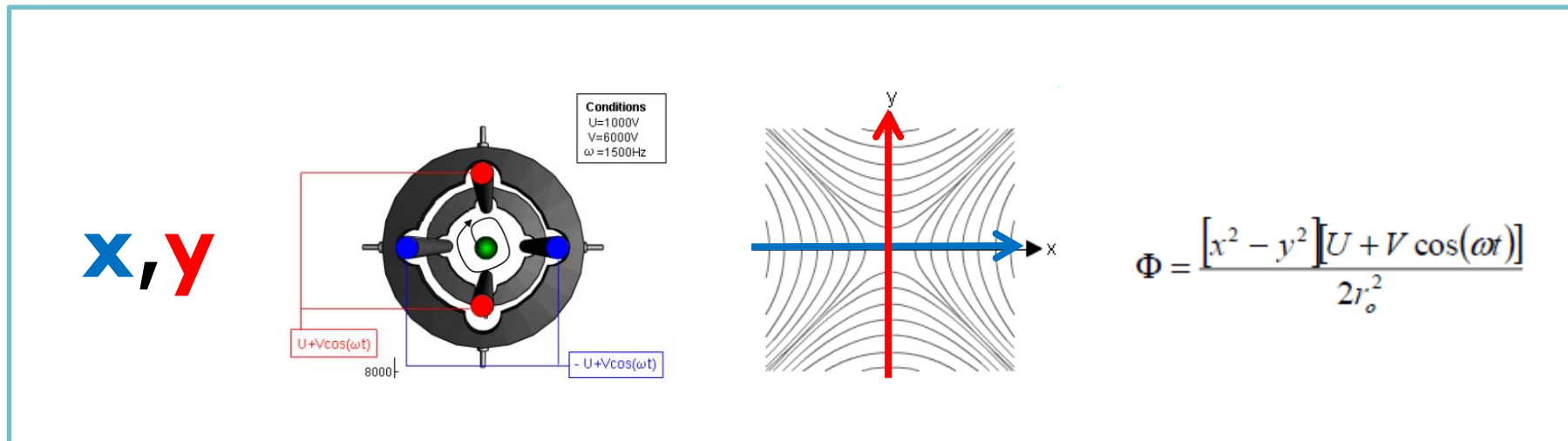

Gyorsítófeszültség, ionoptika

z

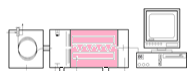
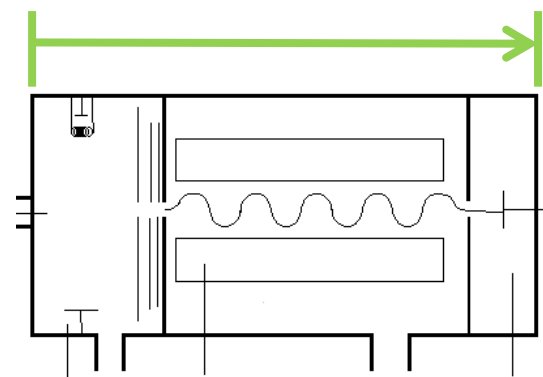
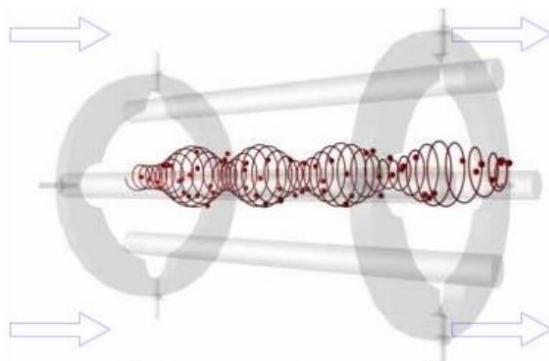

Analizátor Kvadrupól

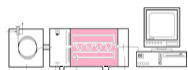
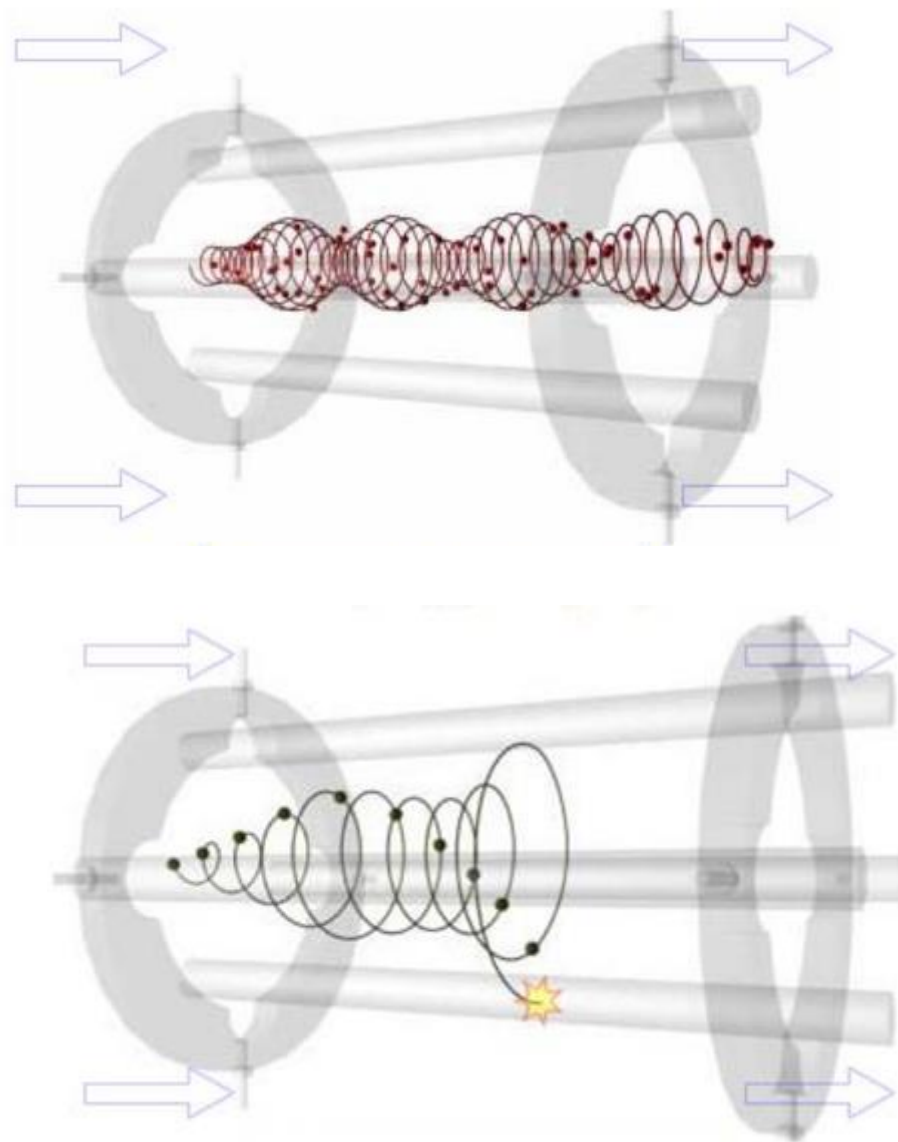

Analizátor: kvadrupól

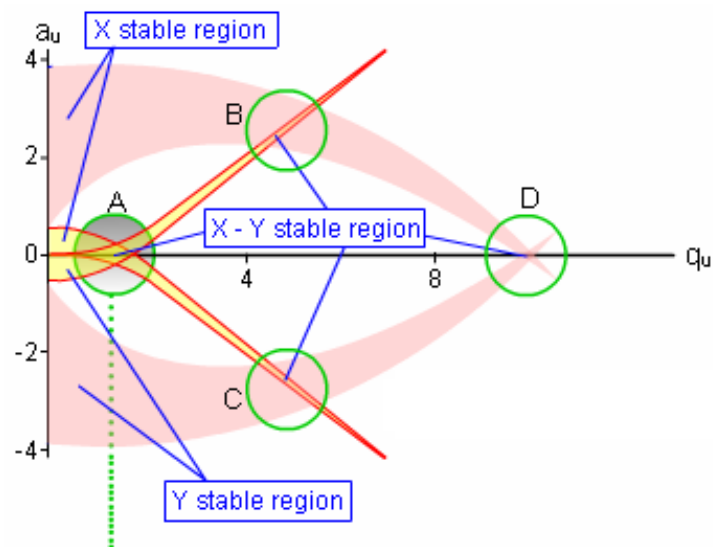

$$\Phi = \frac{[x^2 - y^2][U + V \cos(\omega t)]}{2r_o^2}$$

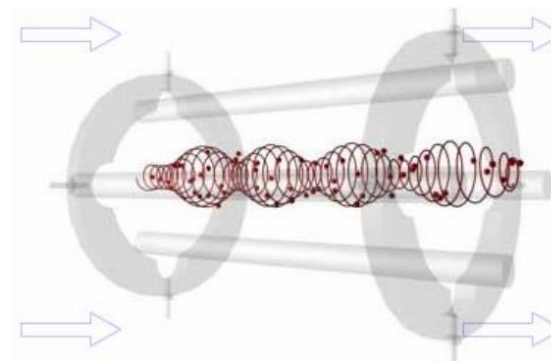
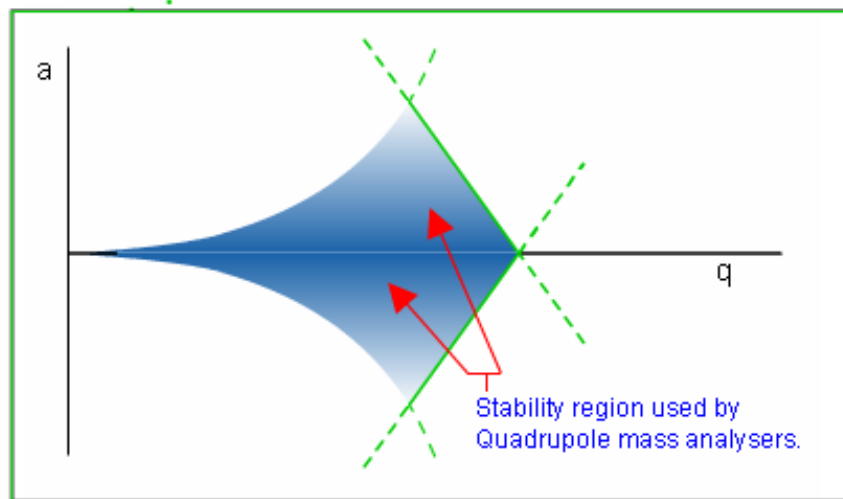
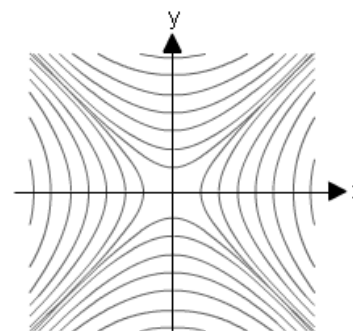

Analizátor: kvadrupól

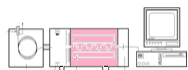
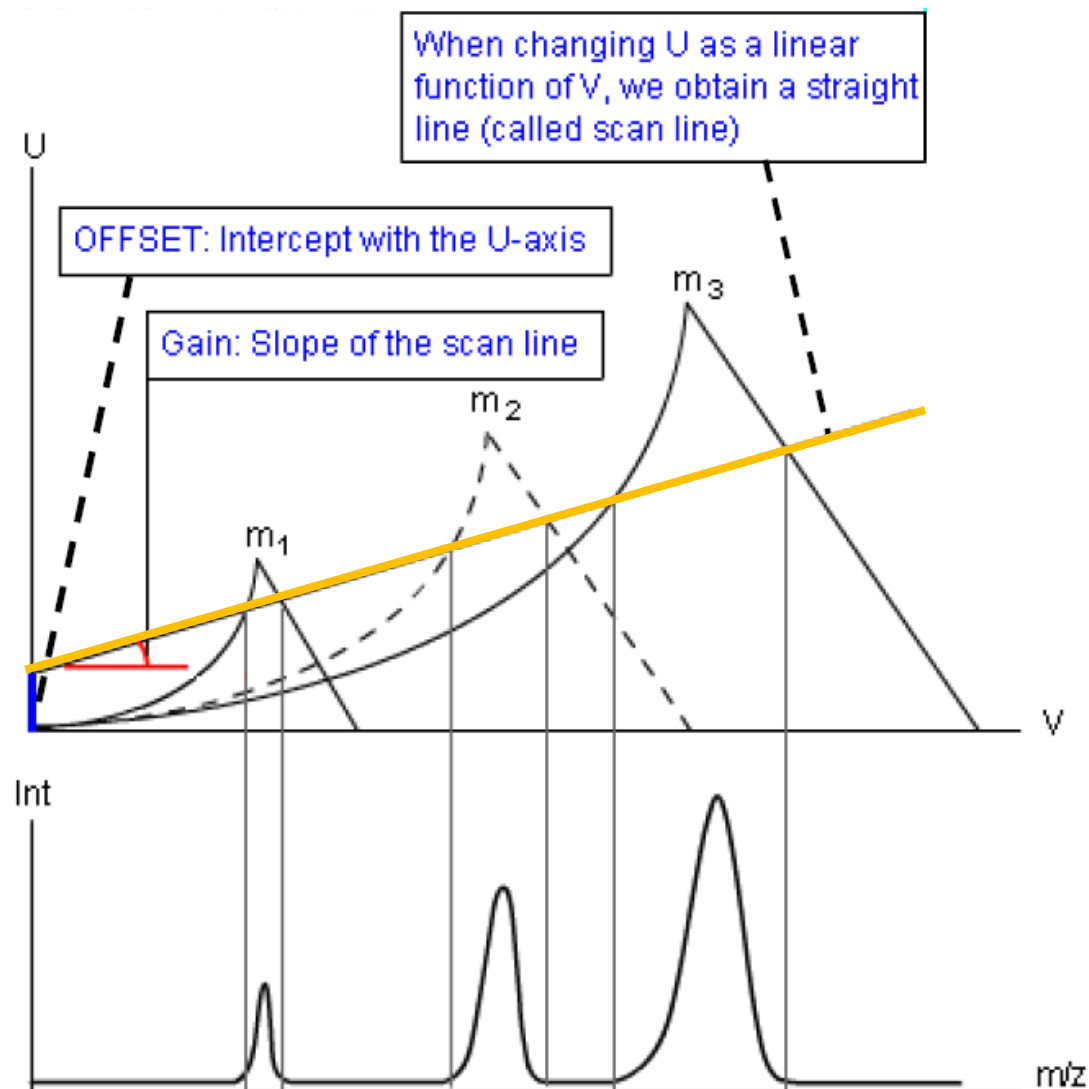

Analizátor: kvadrupól

Gain

Masses m_1 , m_2 , and m_3 are allowed to pass across the quadrupole, masses m_2 and m_3 are not resolved

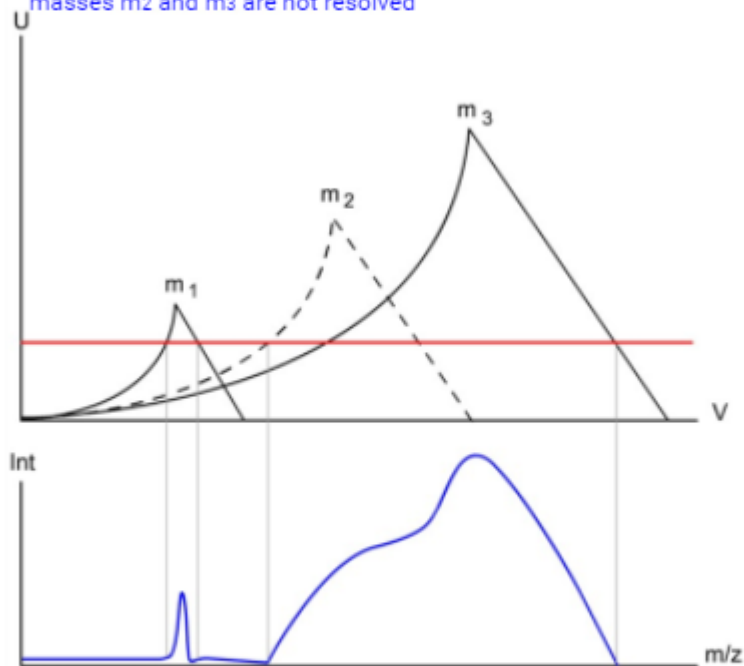

Increasing mass gain

Quadrupole Gain

Quadrupole Offset

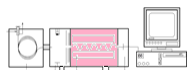

Analizátor: kvadrupól

Gain

Masses m_1 , m_2 , and m_3 are allowed to pass across the quadrupole

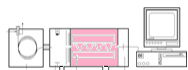
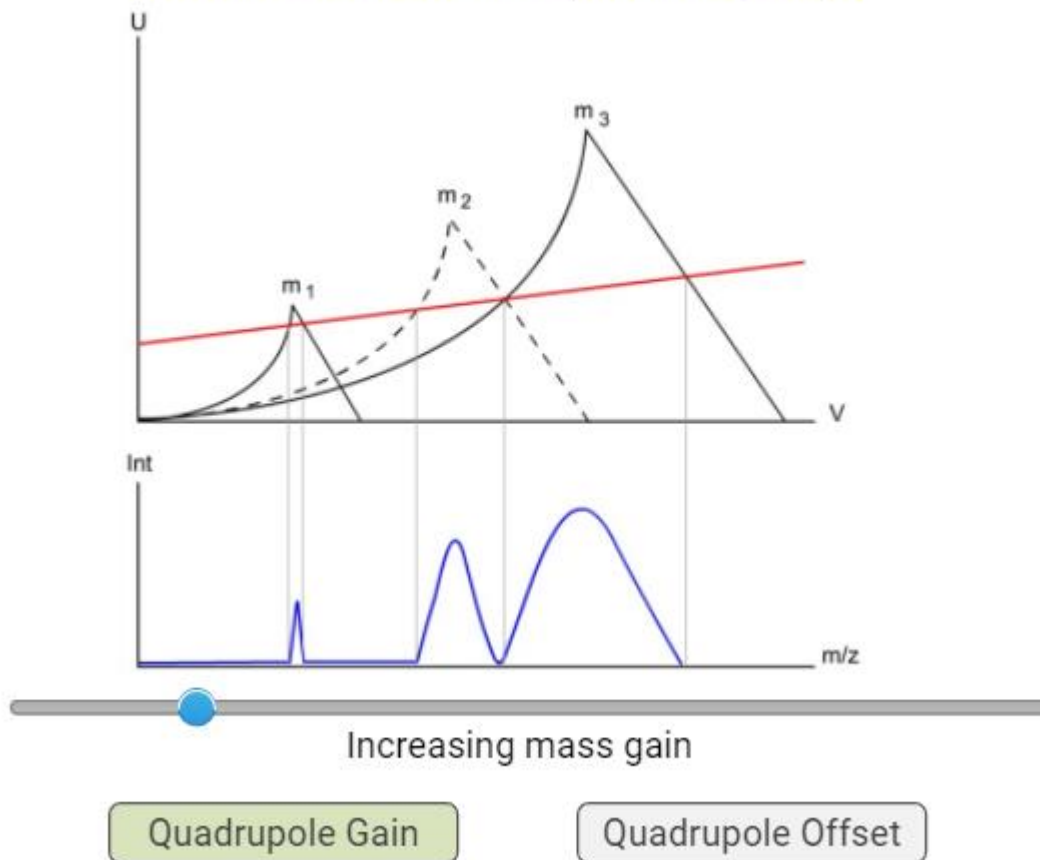

Analizátor: kvadrupól

Gain

Only masses m_2 , and m_3 are allowed to pass across the quadrupole

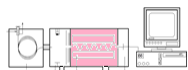
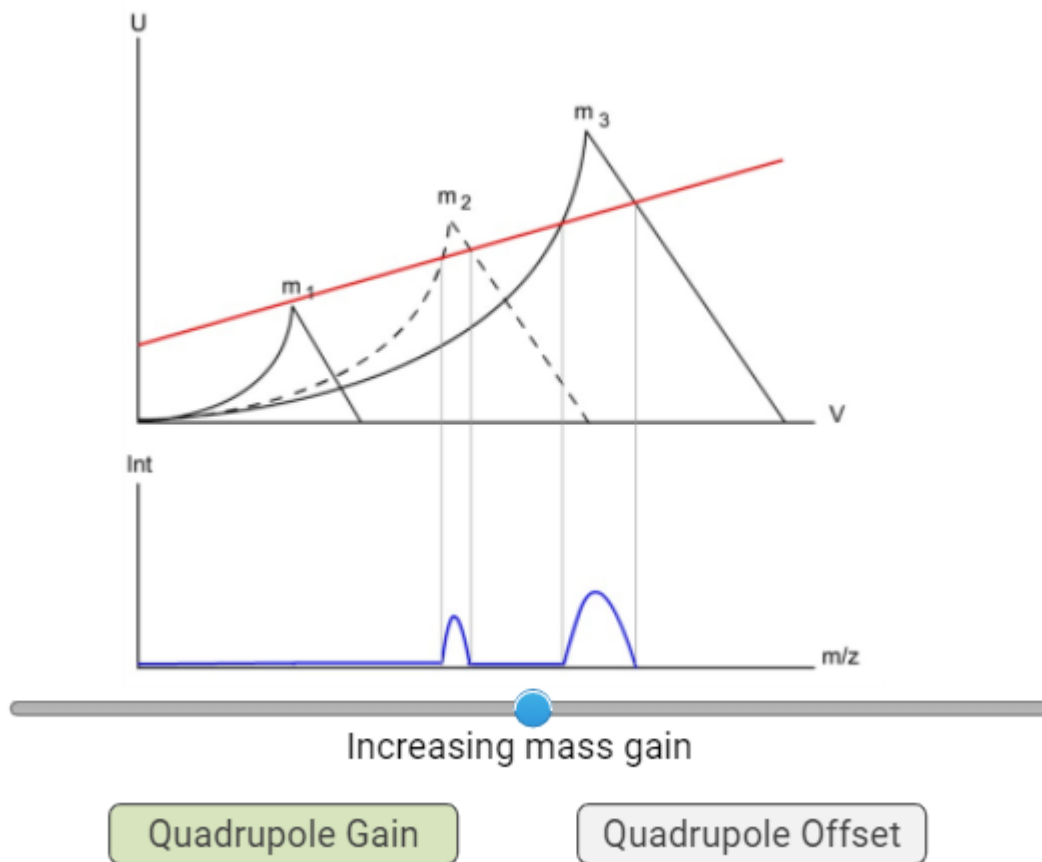

Analizátor: kvadrupól

Gain

Only masses m_2 , and m_3 are allowed to pass across the quadrupole

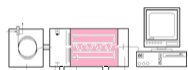
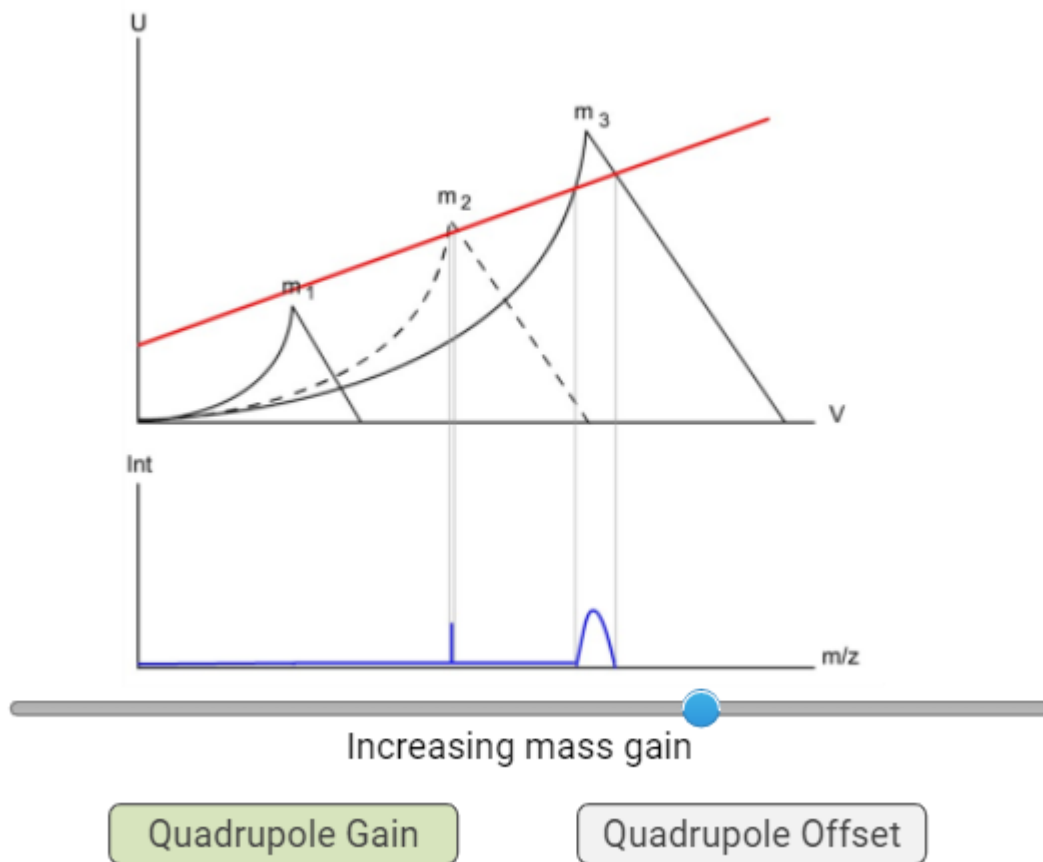

Analizátor: kvadrupól

Gain

If the gain is increased too much in such a way that the scan line misses the apex of any region, no ions of any m/z value will be transmitted

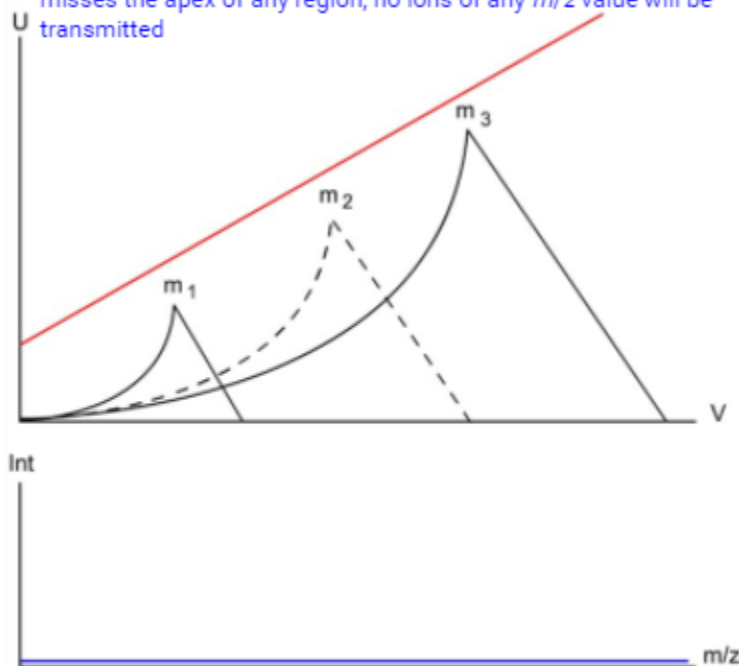

Increasing mass gain

Quadrupole Gain

Quadrupole Offset

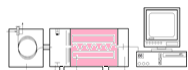

Analizátor: kvadrupól

Offset

Masses m_1 , m_2 , and m_3 are allowed to pass across the quadrupole, masses m_2 and m_3 are not resolved

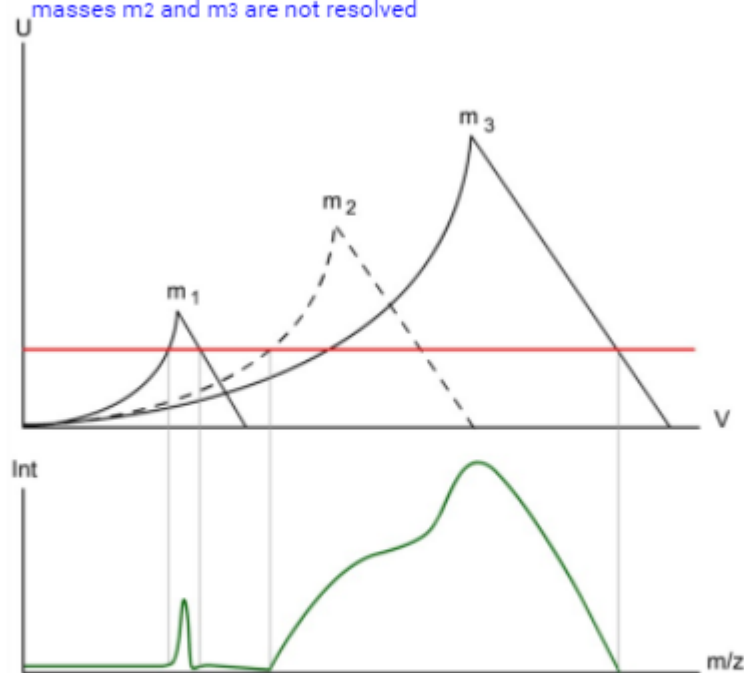

Increasing offset

Quadrupole Gain

Quadrupole Offset

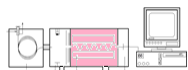

Analizátor: kvadrupól

Offset

Masses m_1 , m_2 , and m_3 are allowed to pass across the quadrupole

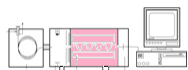
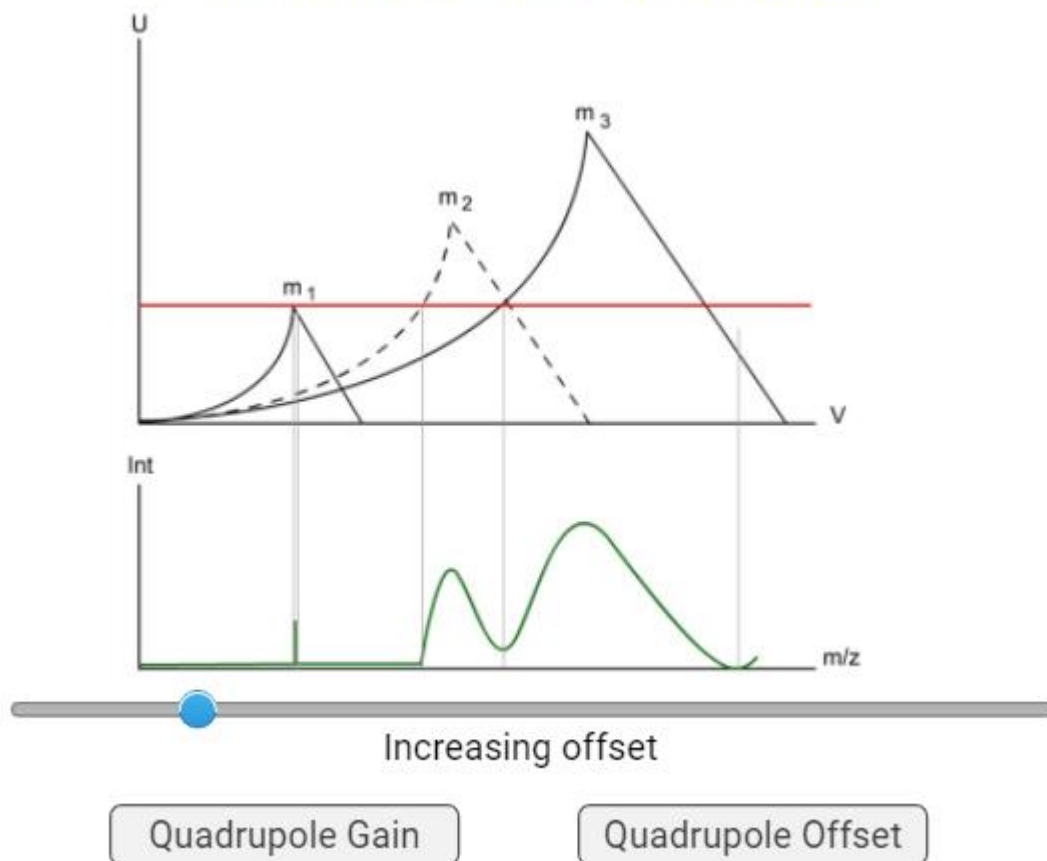

Analizátor: kvadrupól

Offset

Only masses m_2 and m_3 are allowed to pass across the quadrupole

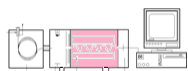
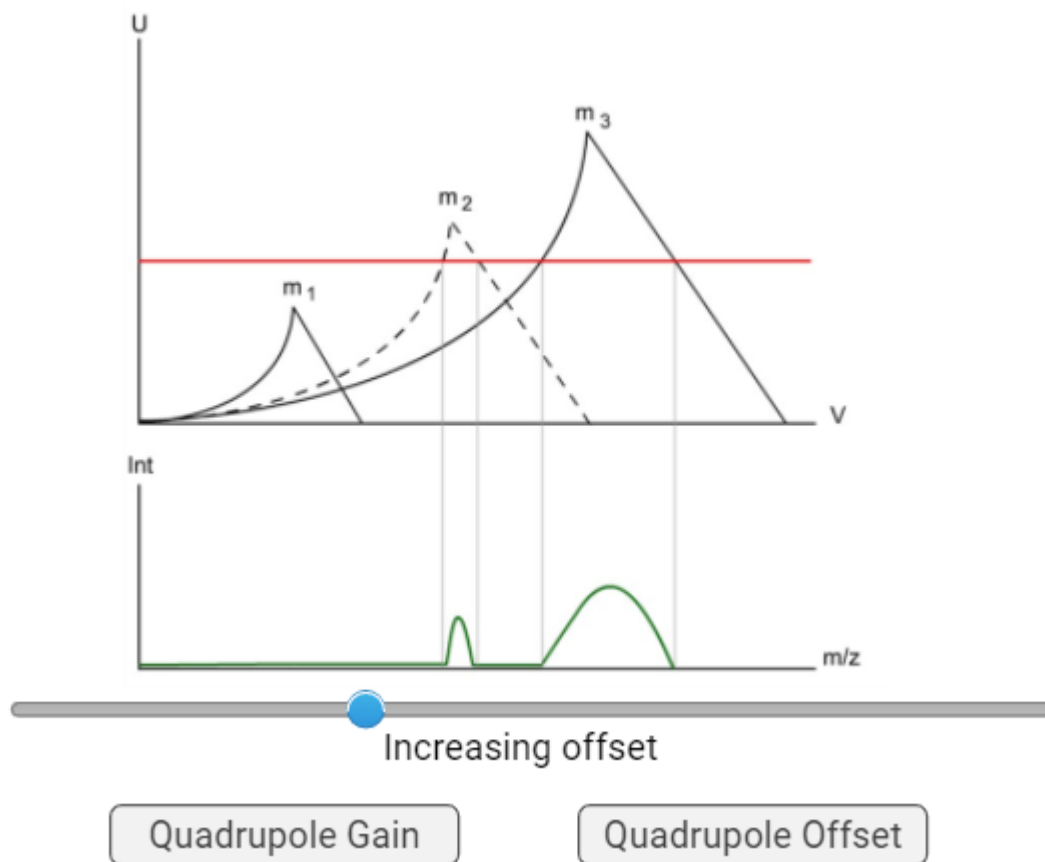

Analizátor: kvadrupól

Offset

Only mass m_3 is allowed to pass across the quadrupole

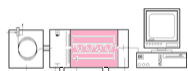
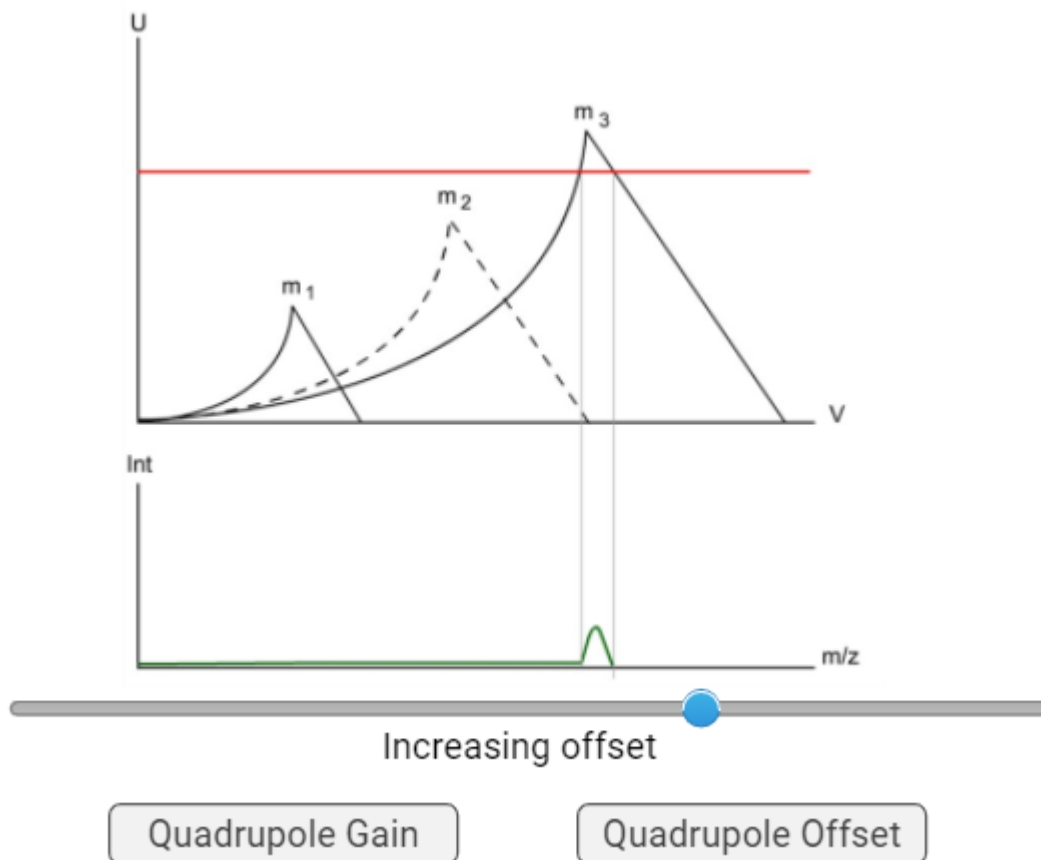

Analizátor: kvadrupól

Offset

If the gain is increased too much in such a way that the scan line misses the apex of any region, no ions of any m/z value will be transmitted

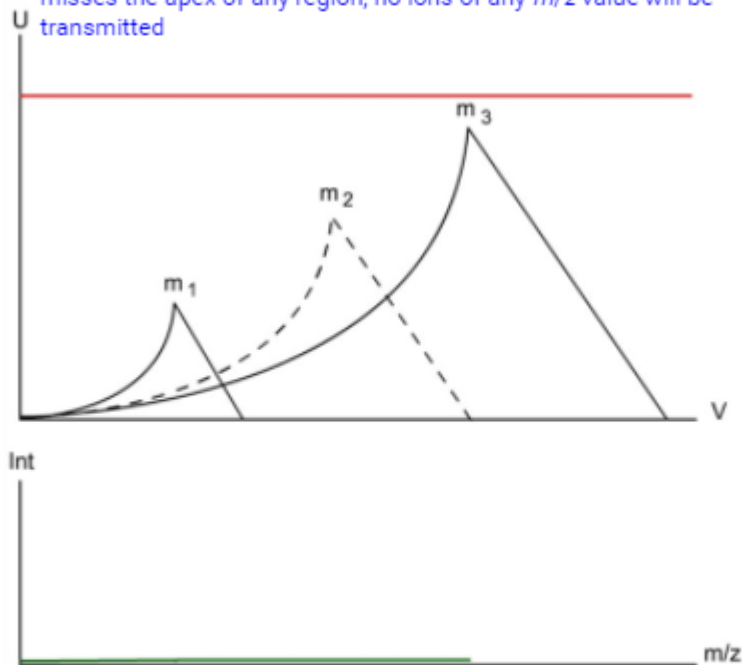

Quadrupole Gain

Quadrupole Offset

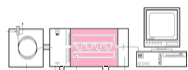

Analizátor: kvadrupól

Ion Bridge

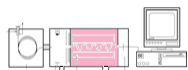
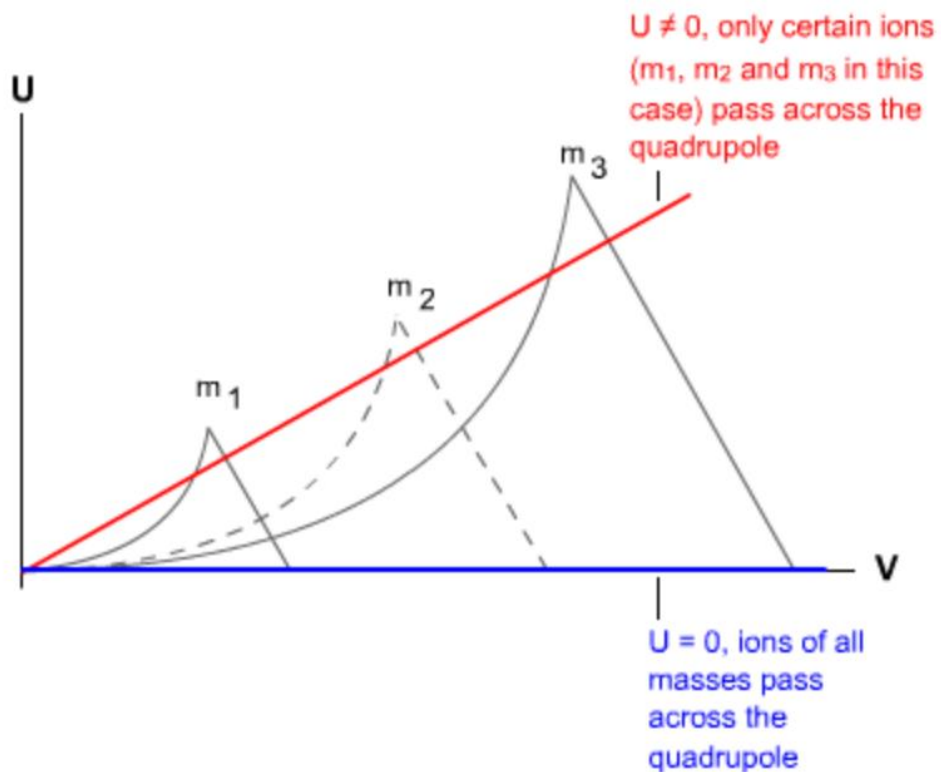

Analizátor felbontóképessége

Felbontóképesség:

$$R = \frac{m}{\Delta m}$$

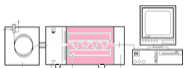
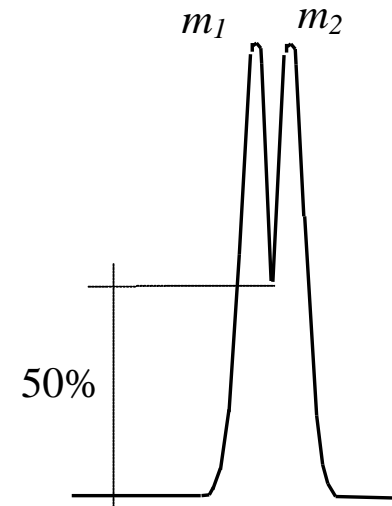
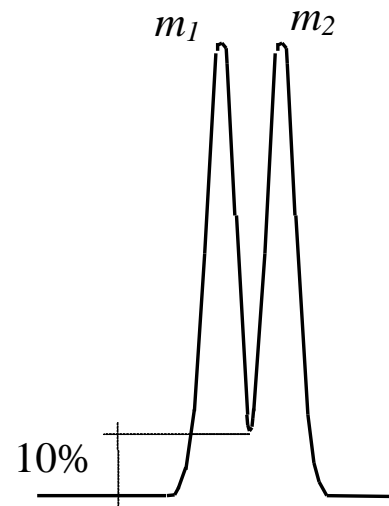
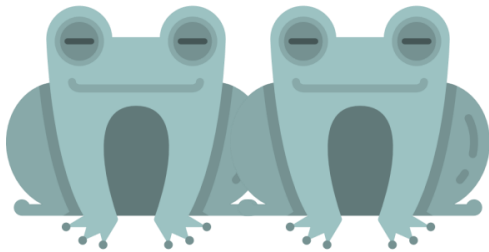

Tömegspektrumok

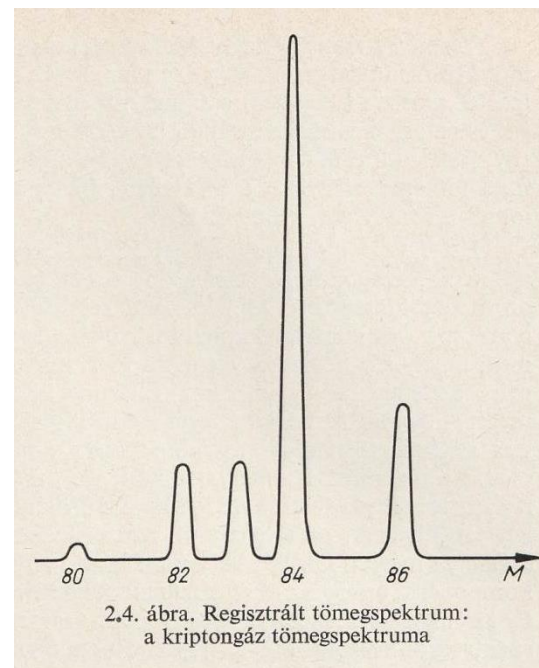
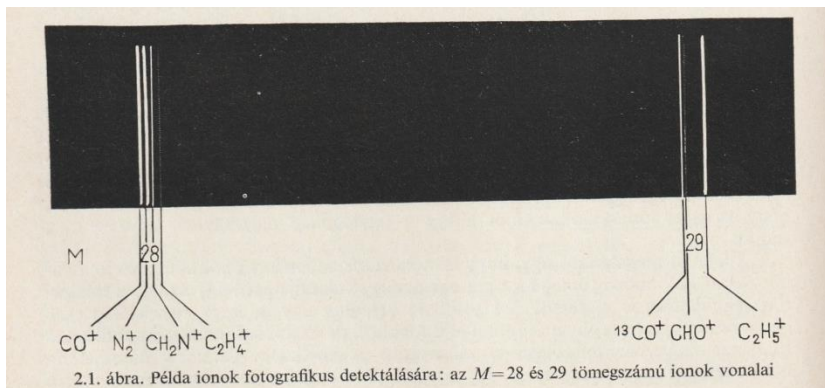

3.3. táblázat

A metán karakterisztikus tömegspektruma mérési adatok alapján

Csúcs- magas- ság	Tömegszám, M							
	1	2	12	13	14	15	16	17
Mért, y_M, mm	17,0	0,8	6,2	19,7	39,1	206,6	240,0	2,6
Relatív*, $r_{jM}, \%$	7,1	0,34	2,6	8,2	16,3	86,1	100,0	1,1

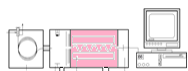
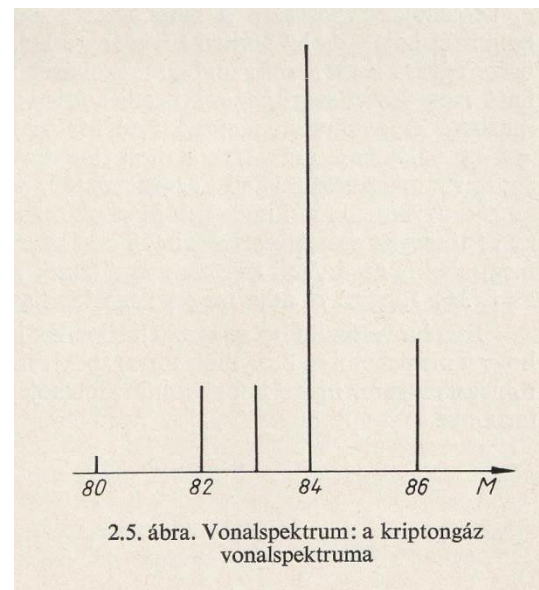

Analizátor felbontóképessége

Felbontóképesség:

$$R = \frac{m}{\Delta m}$$

$$R < 10^4$$

- **kis** felbontóképességű tömegspektrométer
- *analitikai* célú analizátor

$$R > 10^4$$

- **nagy** felbontóképességű tömegspektrométer
- *szerkezetvizsgálati* célú analizátor

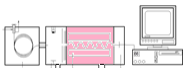

Pontos tömeg = elemösszetétel

szerkezeti információ !

- $C_{20}H_{44}N_3O_6$ 422,322991 amu
- $C_{20}H_{46}N_4O_3$ 422,346800 amu
- $C_{22}H_{42}N_6O_2$ 422,336906 amu
- $C_{24}H_{40}NO_5$ 422,290631 amu
- $C_{29}H_{42}O_2$ 422,318464 amu

Detektor

Elektronsokszorozó

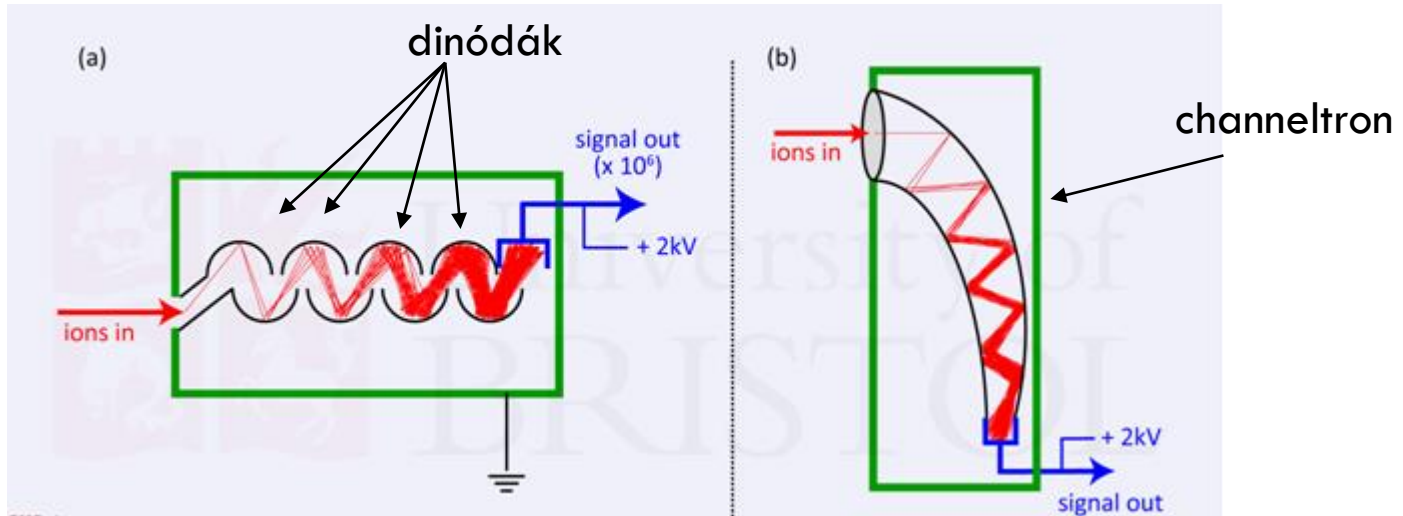

- A dinódák Cd bevonattal vannak ellátva, kicsi az elektronok kilépési munkája.
- 16 db dinóda (az ábrán csak 8) 2^{16} db elektront eredményez, tehát 1 db kiütött elektron 2^{16} db szekunder elektront produkál.
- Egy adott m/z ion jelintenzitását a becsapódó fragmens ionok által kiütött primer elektronok mennyisége szabja meg. (Ez azonban függvénye a fragmens ion számszerűen nem ismert tulajdonságának.)



Vákuumrendszerek

Analitikai készülékek: kétfokozatú

1. fokozat:

elővákuum-rotációs szivattyú
(10^2 kPa - 0.1-1 kPa-ig)

2. fokozat:

turbomolekuláris szivattyú
(0.1-1 kPa-ról 10^{-6} - 10^{-7} kPa-ig)

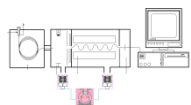

GC-MS-DS

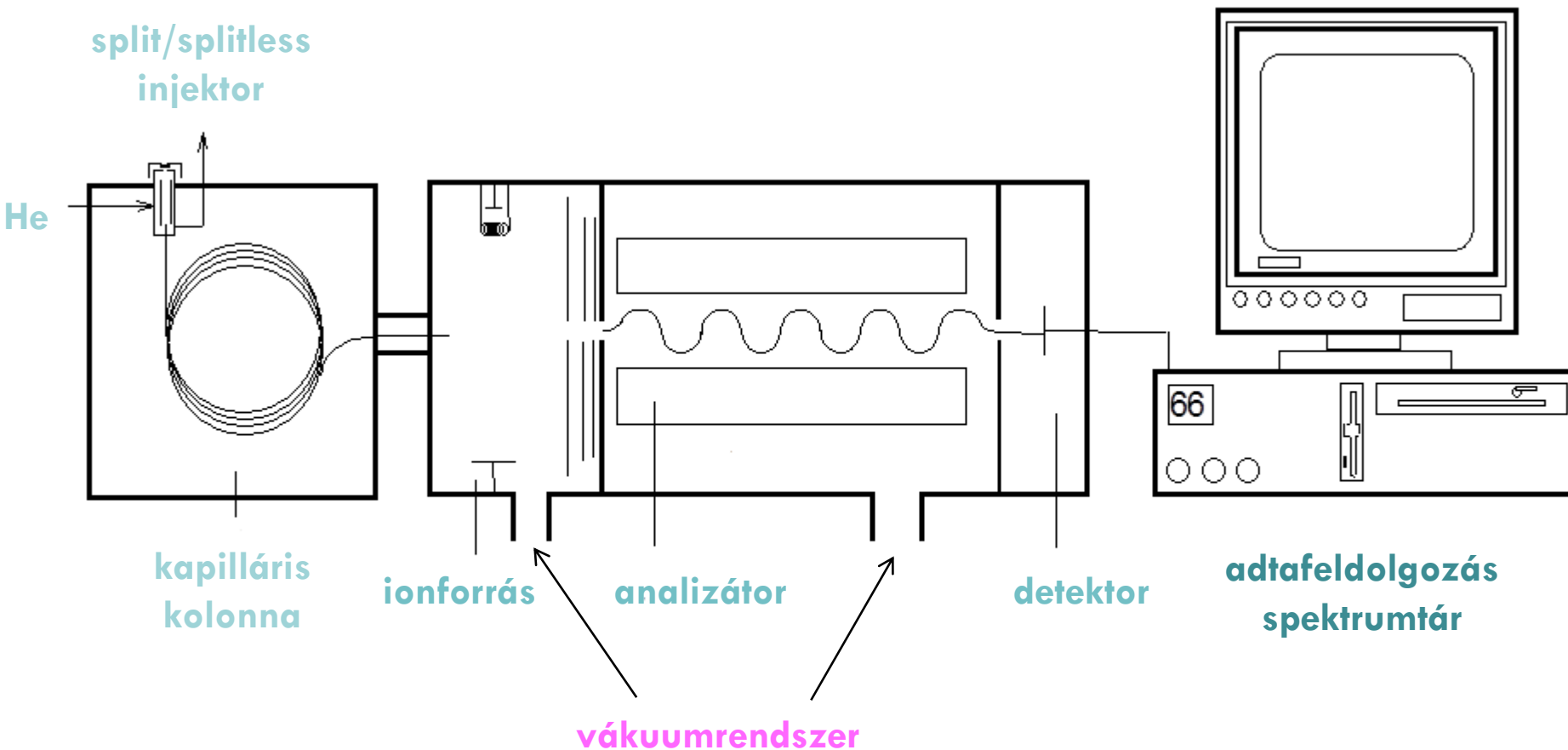

Vákuum ← molekulák szabad úthosszának növelése

GC

MS

DS

Kétfokozatú vákuumrendszer

Olajrotációs szivattyú → elővákuum előállítása

Turbomolekuláris szivattyúk → nagyvákuum előállítása

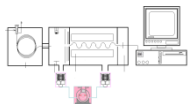
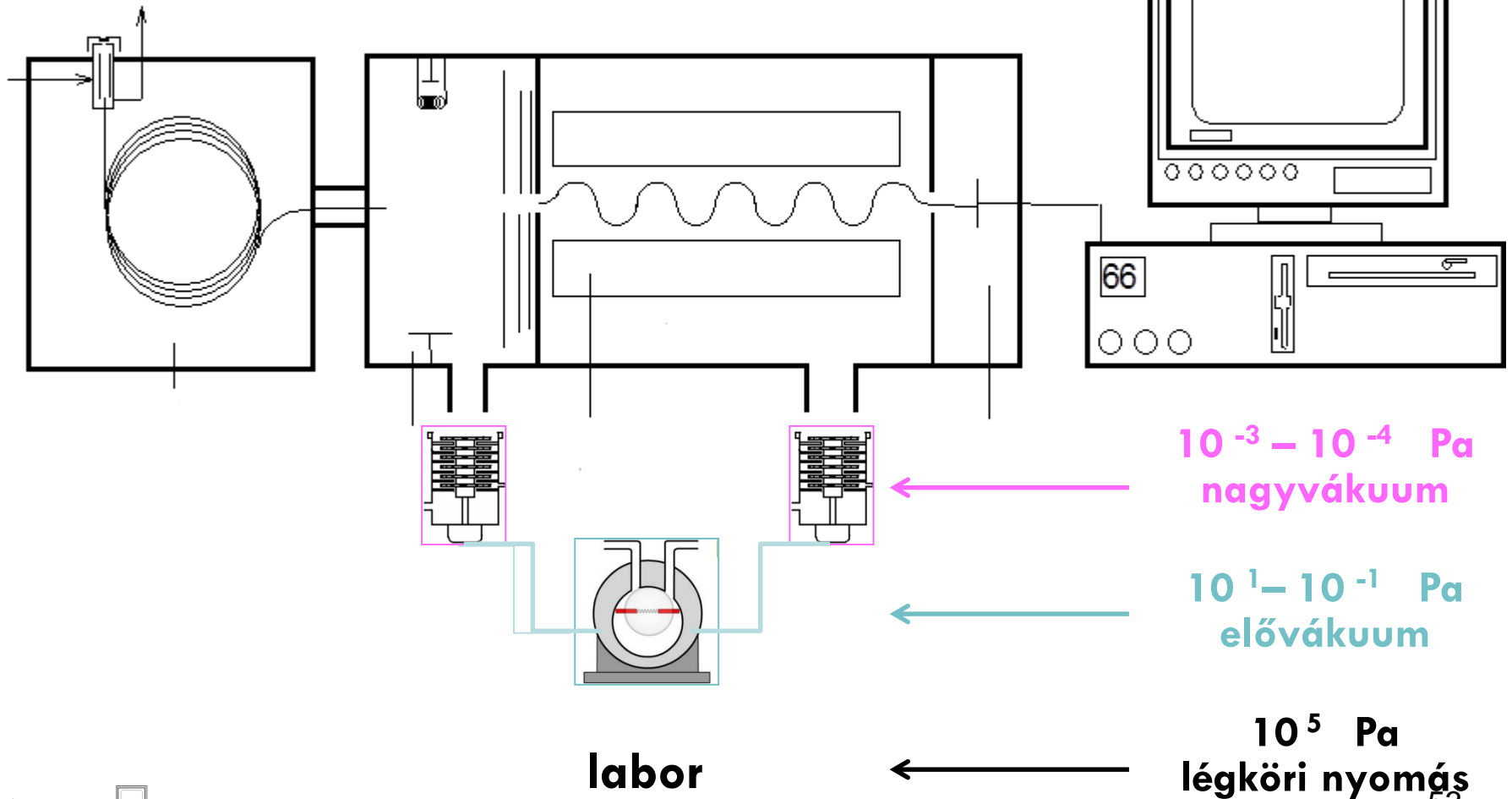

Olajrotációs (csúszólapátos) szivattyú

Elővákuumot hoz létre, $10^1 - 10^{-1}$ Pa

- Excentrikusan csapágyazott forgórész
- Forgás közben növekvő (itt áramlik be a gáz), majd csökkenő térfogatot zárnak be a lapátok
- Centrifugális erő szorítja a lapátokat a falhoz
- Térfogat kiszorításos elv
- Olajozás

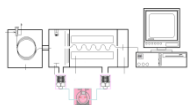
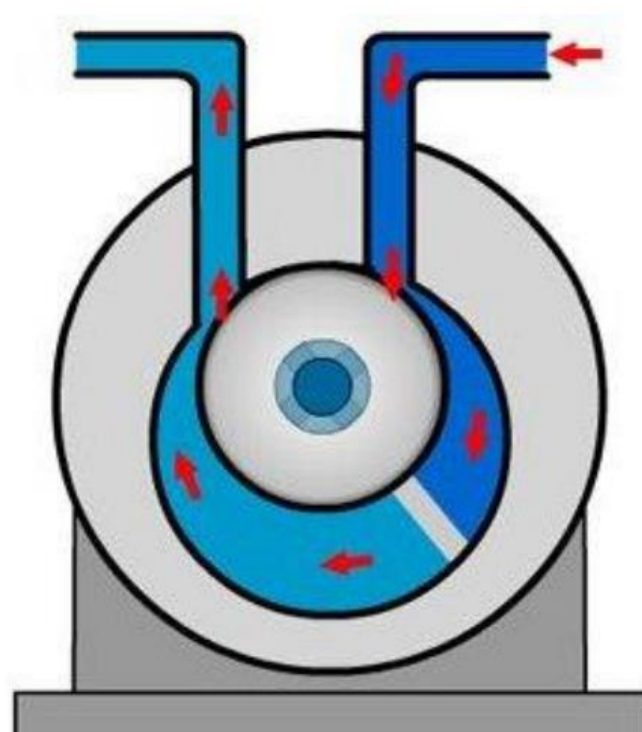

Olajrotációs (csúszólapátos) szivattyú

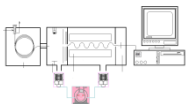
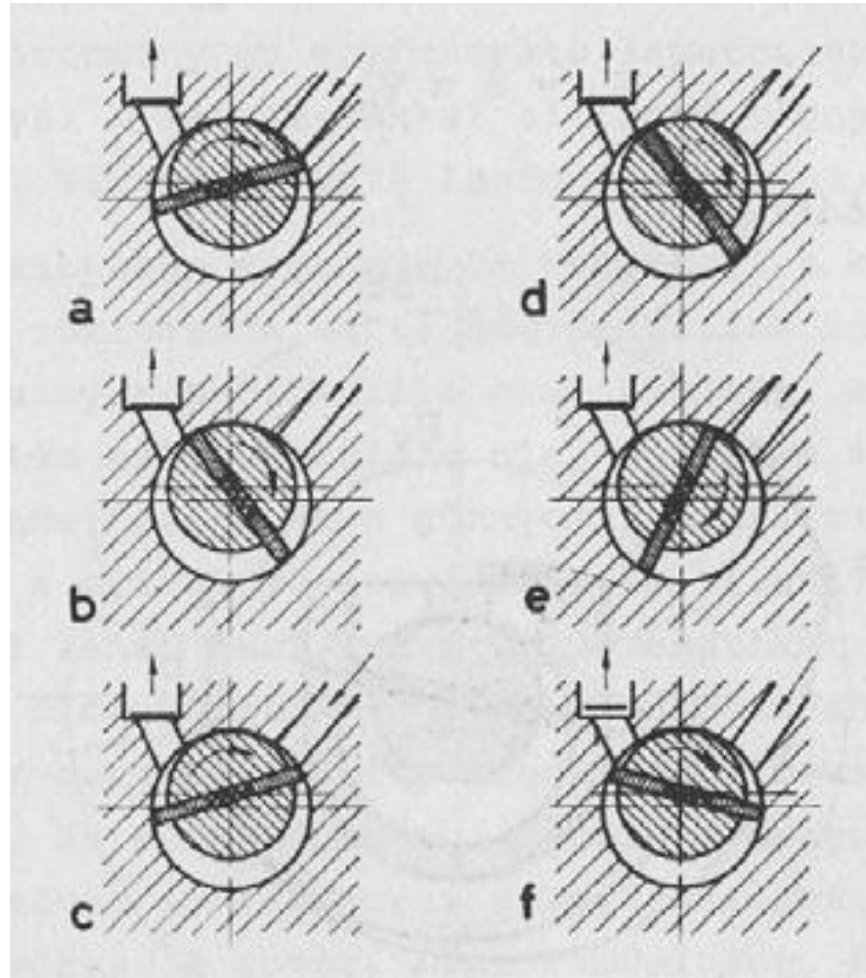

Turbomolekuláris szivattyú

- **Nagyvákuumot hoz létre, $10^{-3} - 10^{-4}$ Pa**
- 50.000-90.000 ford./min, elővákuumra van szüksége
- „kipofozás”

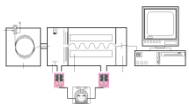
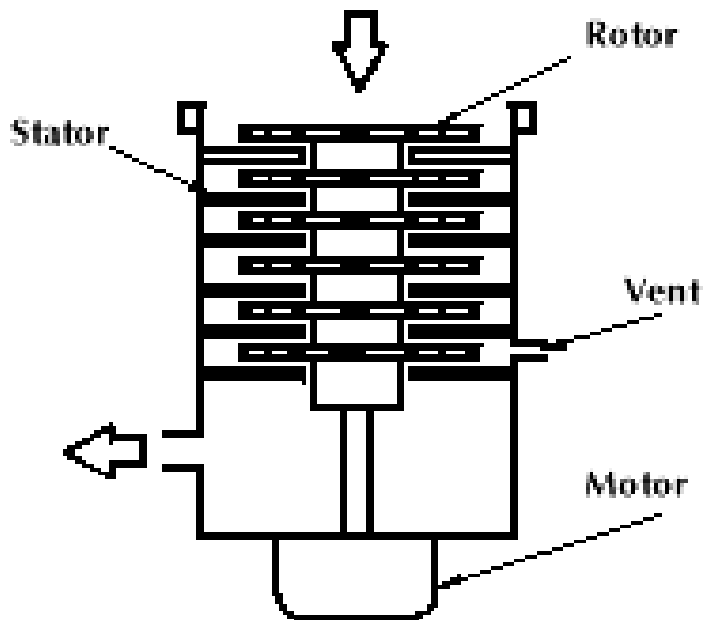

Turbomolekuláris szivattyúk

Q

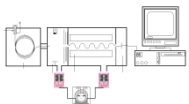
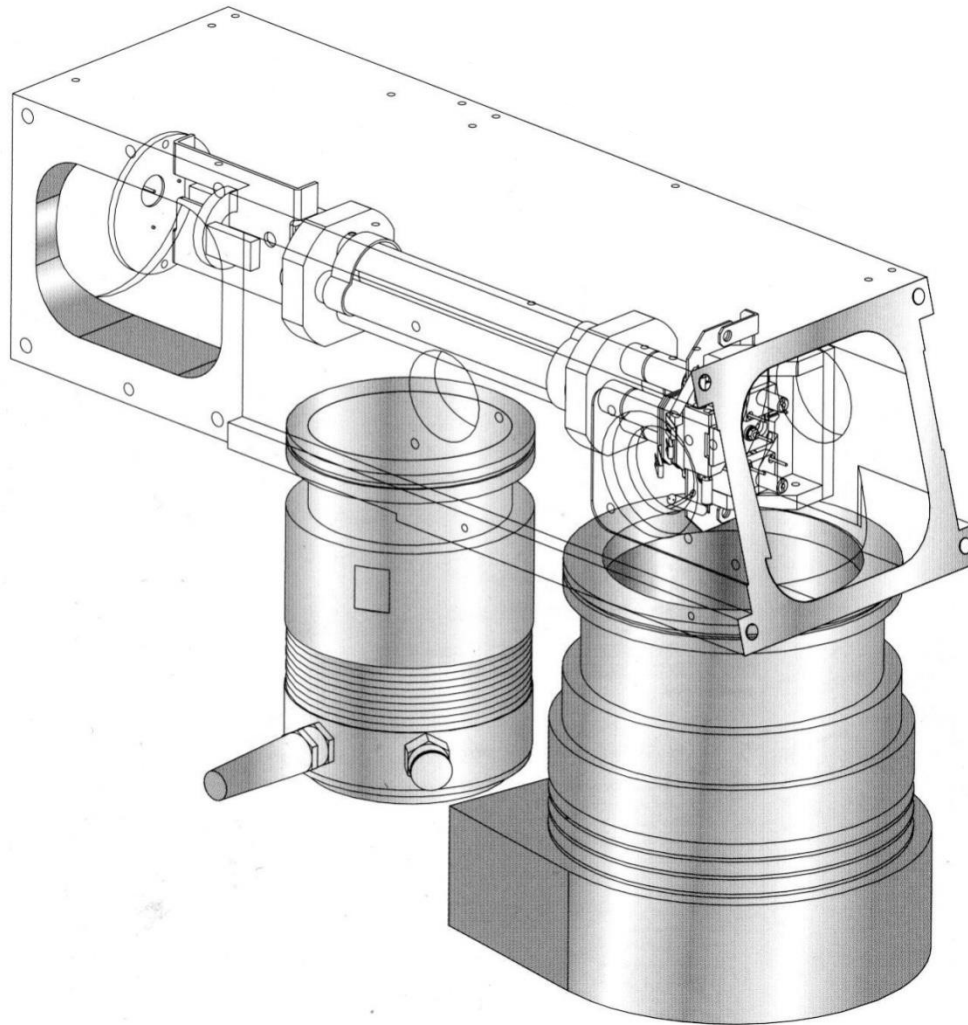

Turbomolekuláris szivattyúk

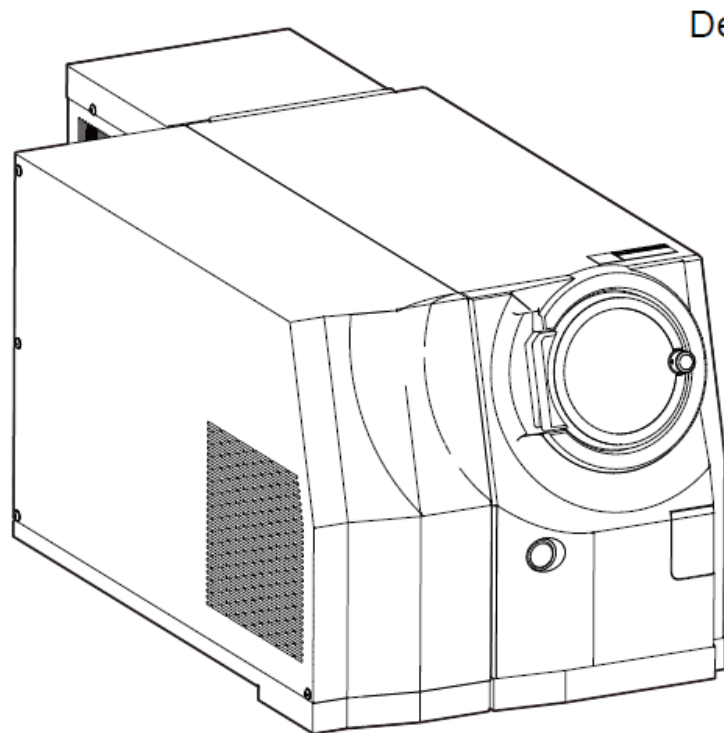

External View

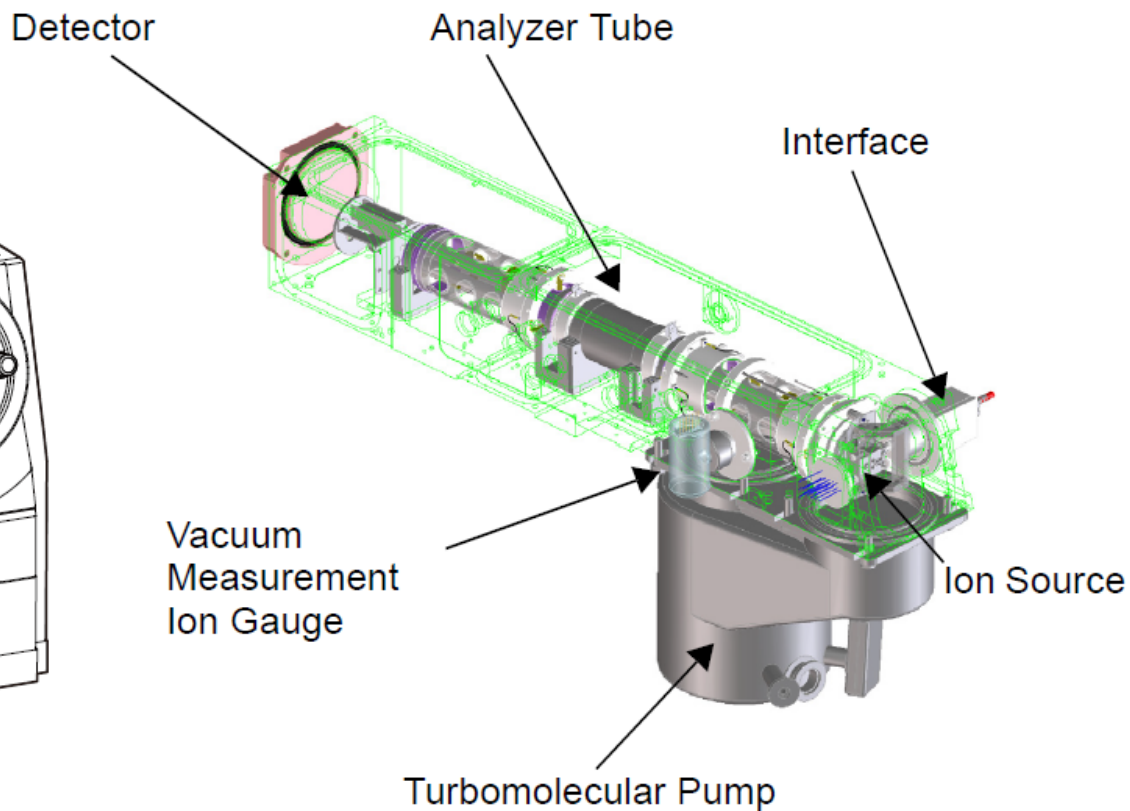

Internal View

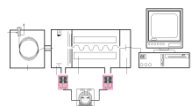

Pirani-cső

- elővákuumot méri
- nyomás mérése hővezetőképesség mérésére visszavezetve

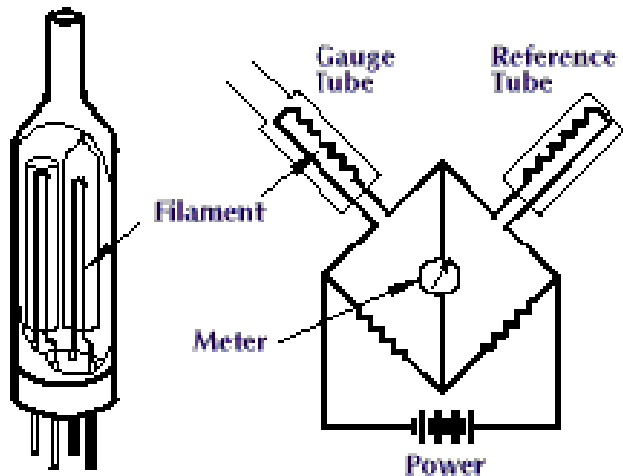

vö: hővezetőképességi detektor

mikro-TCD

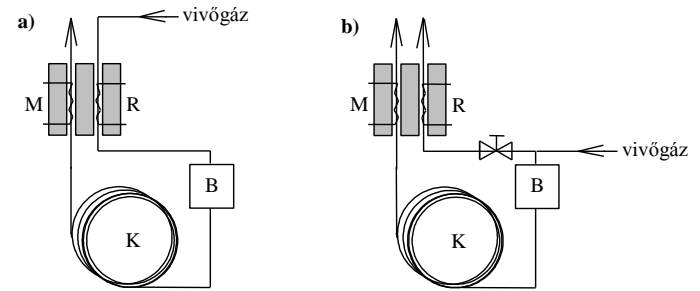

Pirani-cső

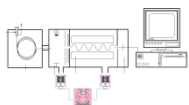

Ionizációs vákuummérő

- nagyvákuumot mér
- ionizációs elven mér

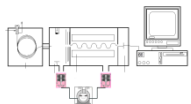
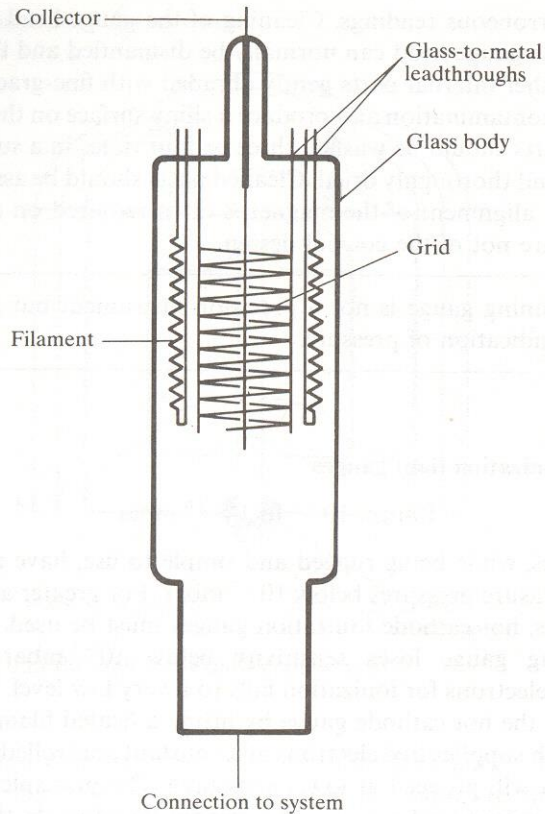

vö: El ionforrás

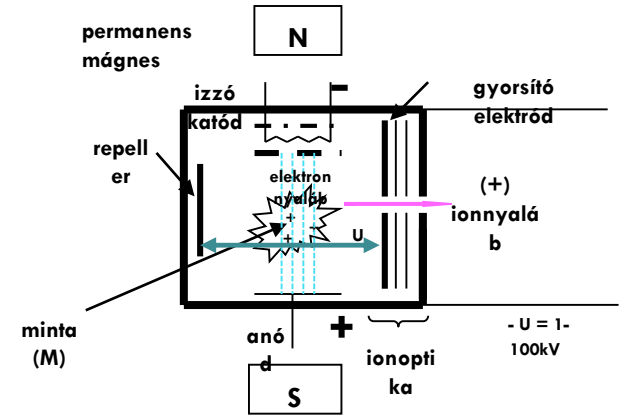

GC-MS rendszerből származó információ

SCAN

SIM

GC-MS rendszerből származó információ

1. kromatogram (TIC, teljes ionáram kromatogram)

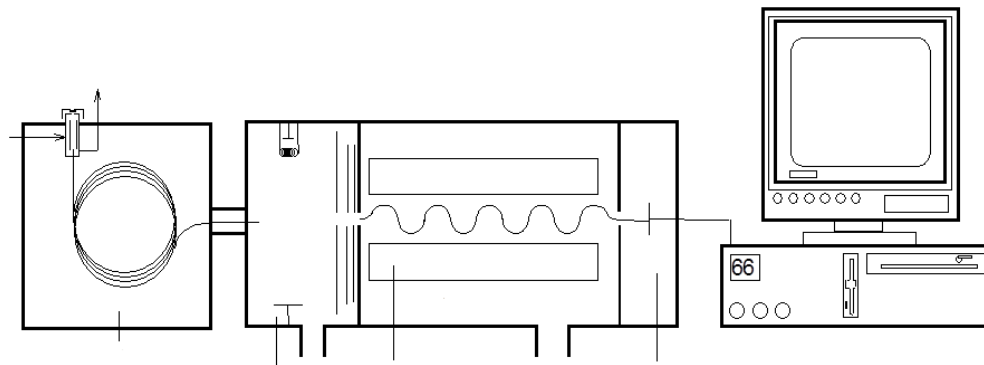
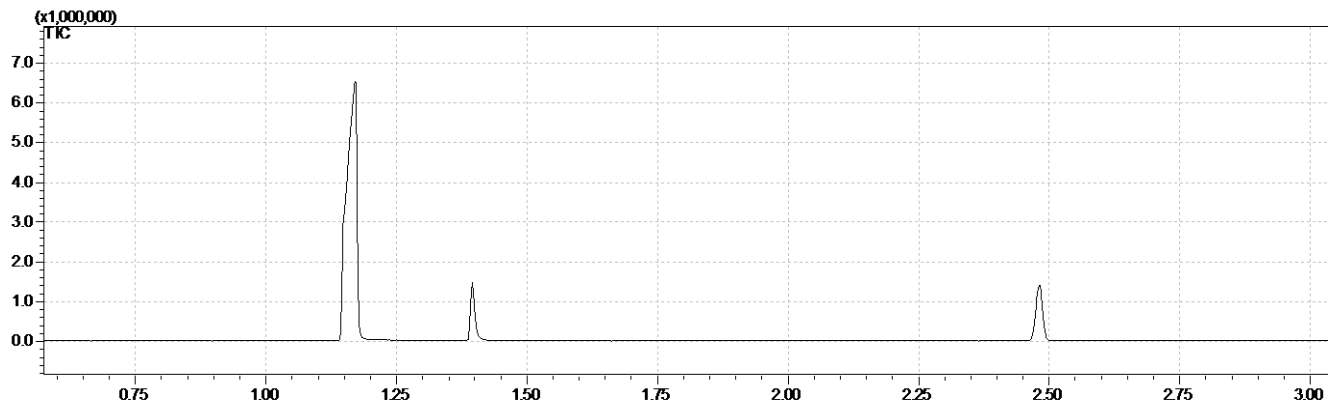

GC-MS rendszerből származó információ

1. kromatogram (TIC, teljes ionáram kromatogram)

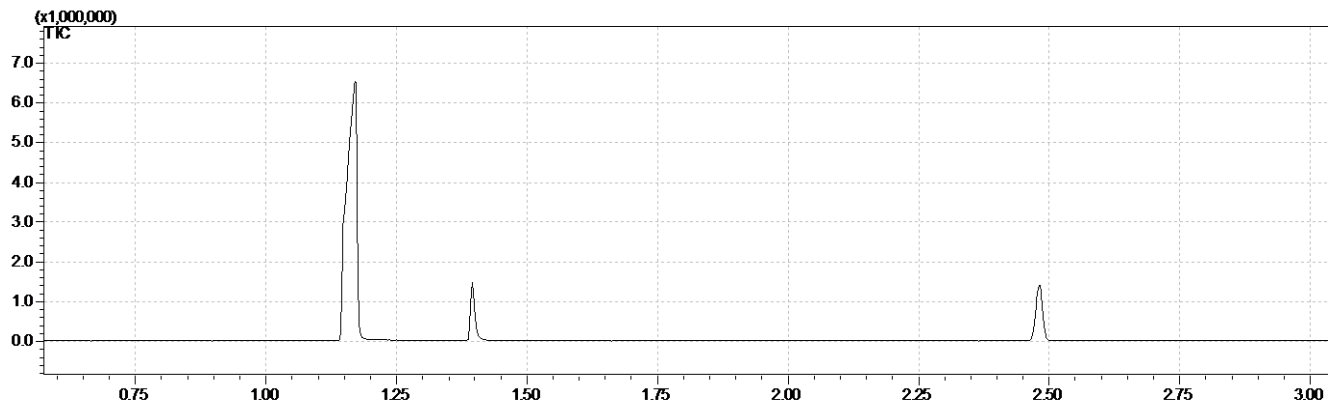

GC-MS rendszerből származó információ

1. kromatogram (TIC, teljes ionáram kromatogram)

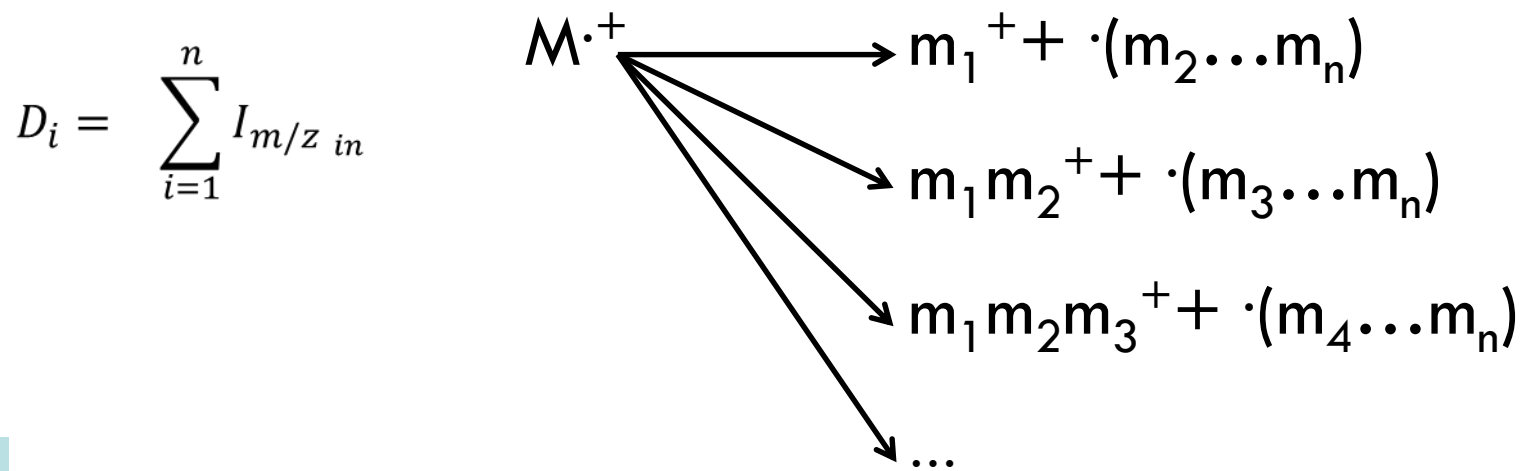
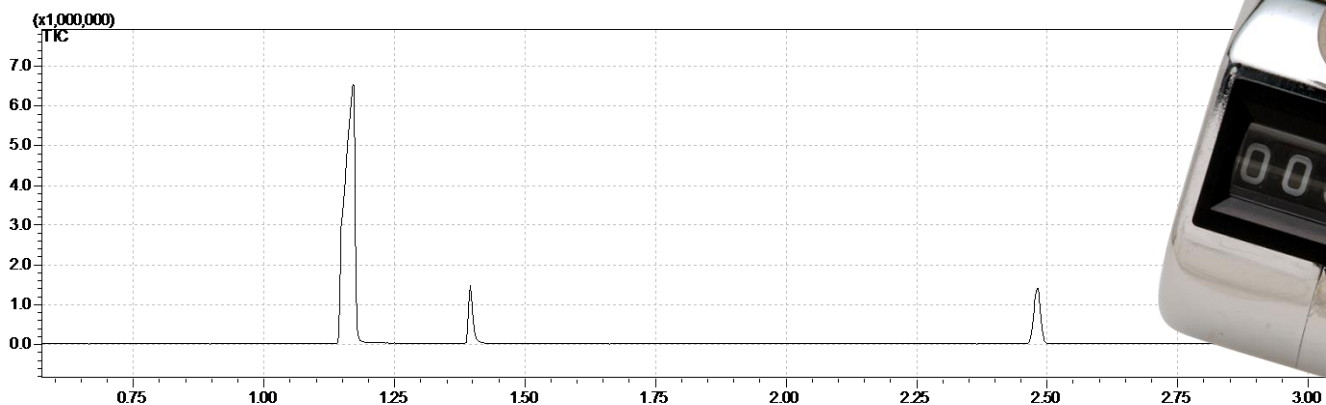

GC-MS rendszerből származó információ

1. kromatogram (TIC, teljes ionáram kromatogram)

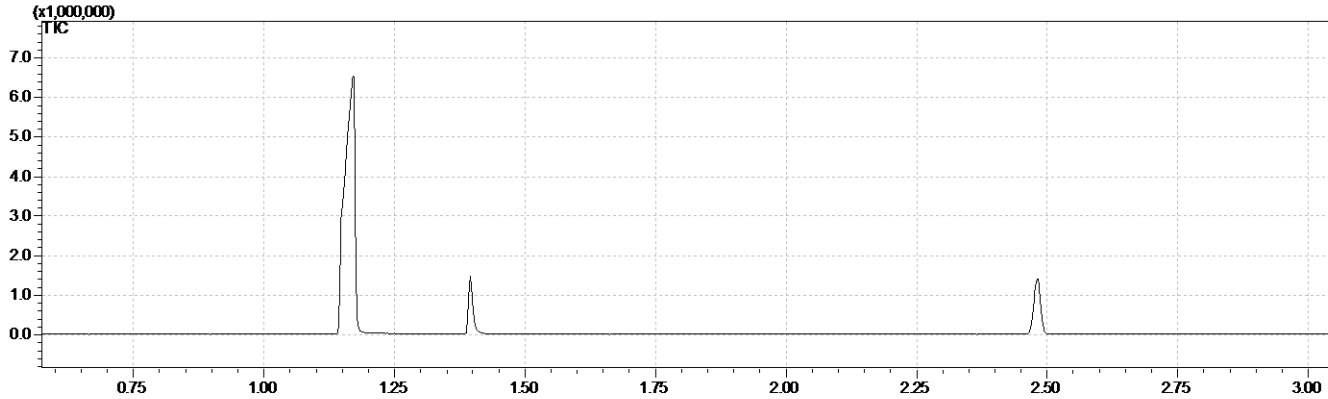

2. tömegspektrum (abszolút, karakterisztikus)

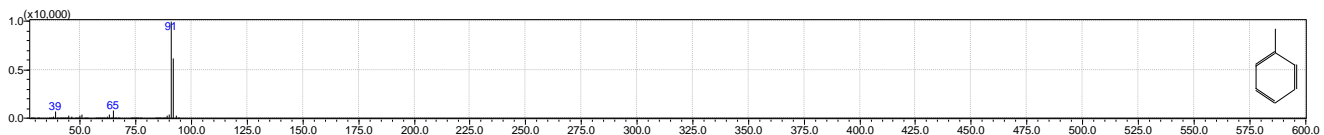
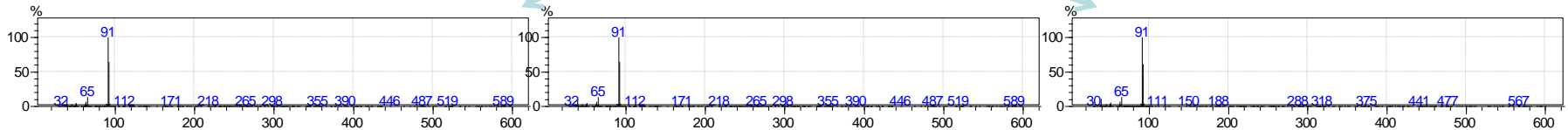
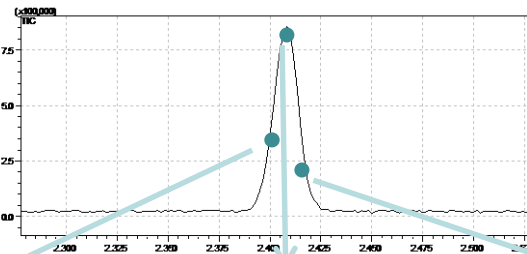

TIC kromatogram

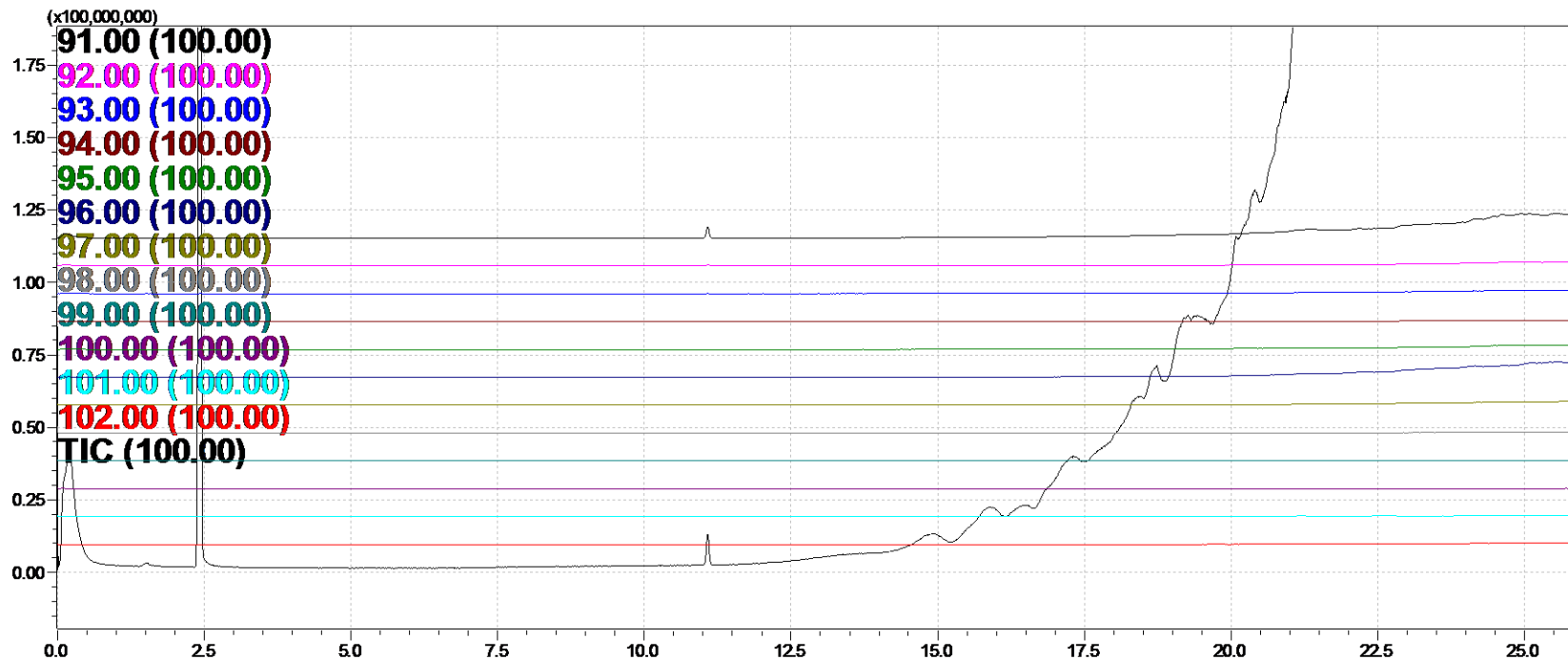

TIC kromatogram

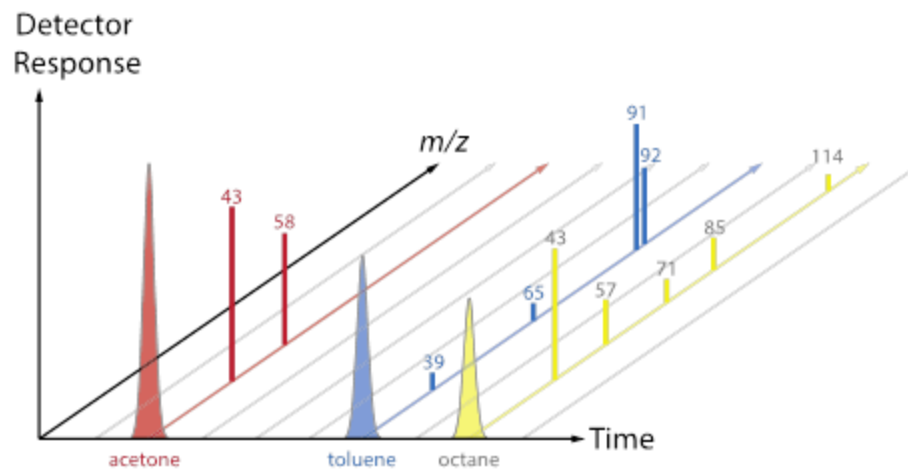

[https://chem.libretexts.org/Bookshelves/Analytical_Chemistry/Supplemental_Modules_\(Analytical_Chemistry\)/Analytical_Sciences_Digital_Library/Active_Learning/In_Class_Activities/Mass_Spectrometry%3A_LEGO_Exercise/Instructor%E2%80%99s_Guide_%E2%80%93_Chromatograms_and_Mass_Spectra](https://chem.libretexts.org/Bookshelves/Analytical_Chemistry/Supplemental_Modules_(Analytical_Chemistry)/Analytical_Sciences_Digital_Library/Active_Learning/In_Class_Activities/Mass_Spectrometry%3A_LEGO_Exercise/Instructor%E2%80%99s_Guide_%E2%80%93_Chromatograms_and_Mass_Spectra)

Karakterisztikus tömegspektrum

- m/z intenzitások bázisonra vannak normálva
- „ujjlenyomat”

toluol ($M = 92 \text{ g/mol}$)

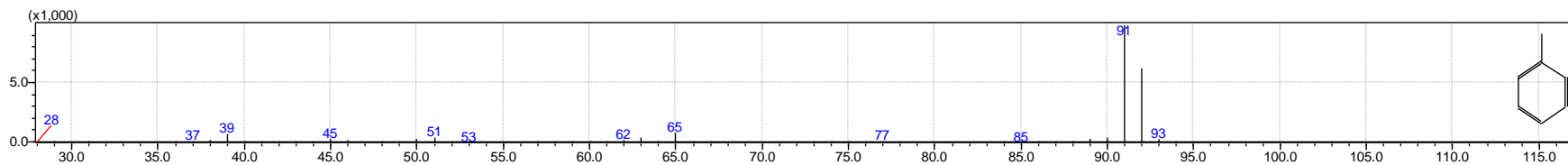

Bázision: 91 m/z

Molekulaion: 92 m/z

Minőségi elemzés

- Minőségi információ
 - retenciós idő
 - karakterisztikus tömegspektrum
 - irodalmi adatbázisokkal való összehasonlítás: NIST, Wiley adatbázisok, 350.000-400.000 MS spektrum
 - spektrumfejtés

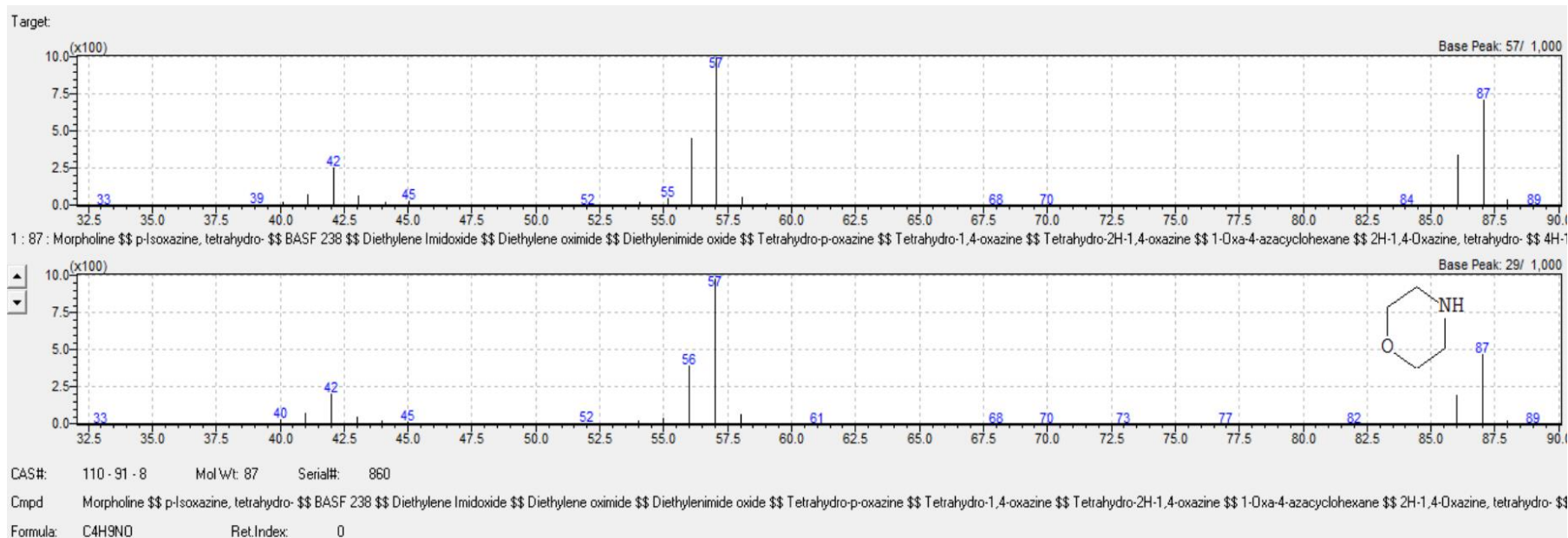

Mennyiségi elemzés

Csúcs alatti terület

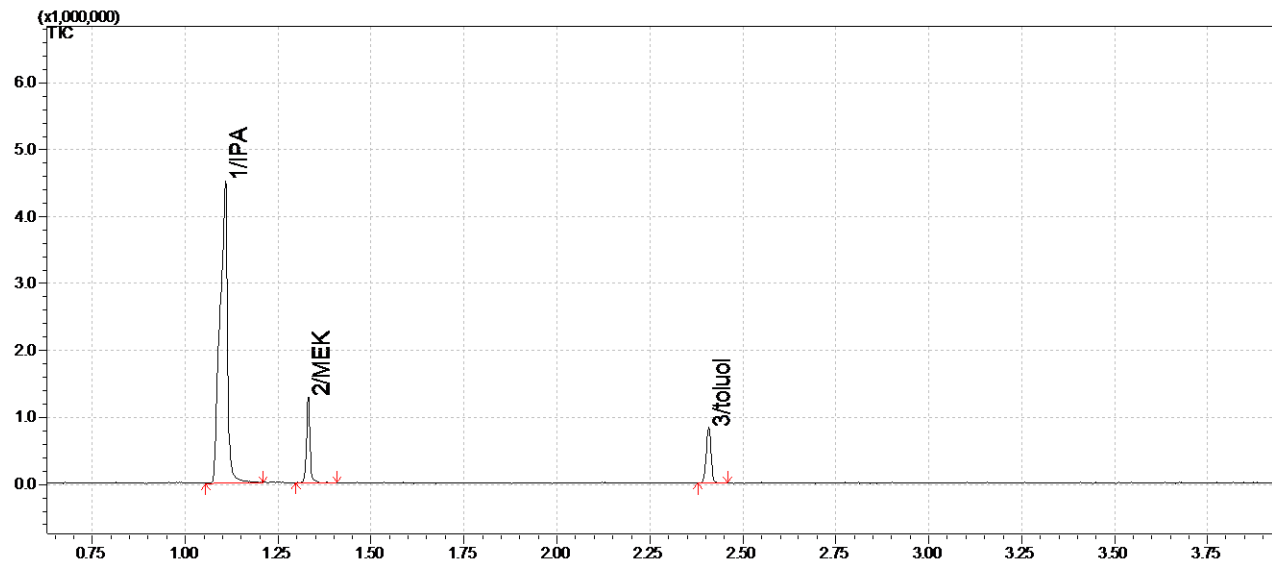

SIM méréstechnika (Selected Ion Monitoring)

szelektív ionkövetés

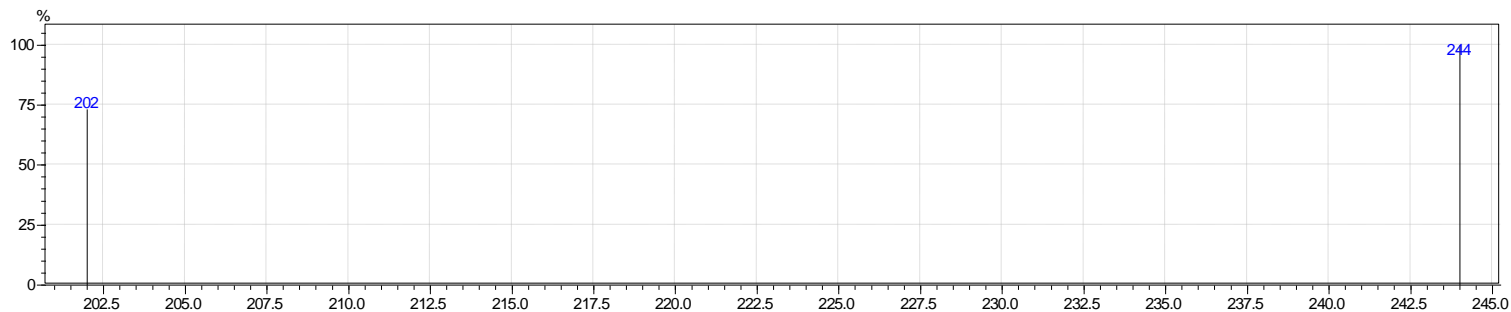
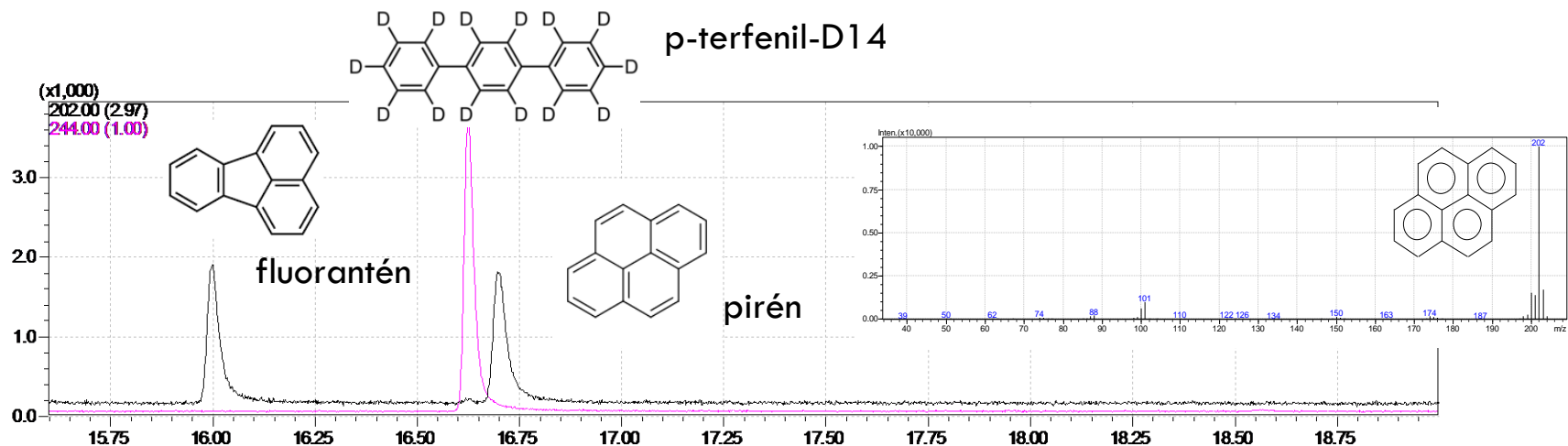

SCAN és SIM mérés technika

Méréskor beállítandó: Tömegtartomány (pl. 30-250 m/z vagy 91 m/z)

Spektrumfelvételi idő (0,1-1 sec)

- **SCAN** mód: teljes tömegskálát pásztáz (szkennel) végig,
eredménye : tömegspektrum
kromatogram generálás: minőségi, mennyiségi analízis
- **SIM** mód: Szelektív ionkövetés (Selected Ion Monitoring),
egy vagy több kiválasztott fragmens mérése,
kisebb a kimutatási határ a scan felvételhez képest:
mennyiségi analízis

GC-MS rendszerből származó információ

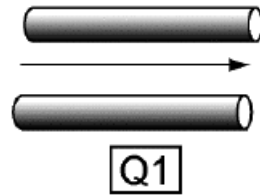

SCAN

SIM

GC-MS/MS rendszerből származó információ

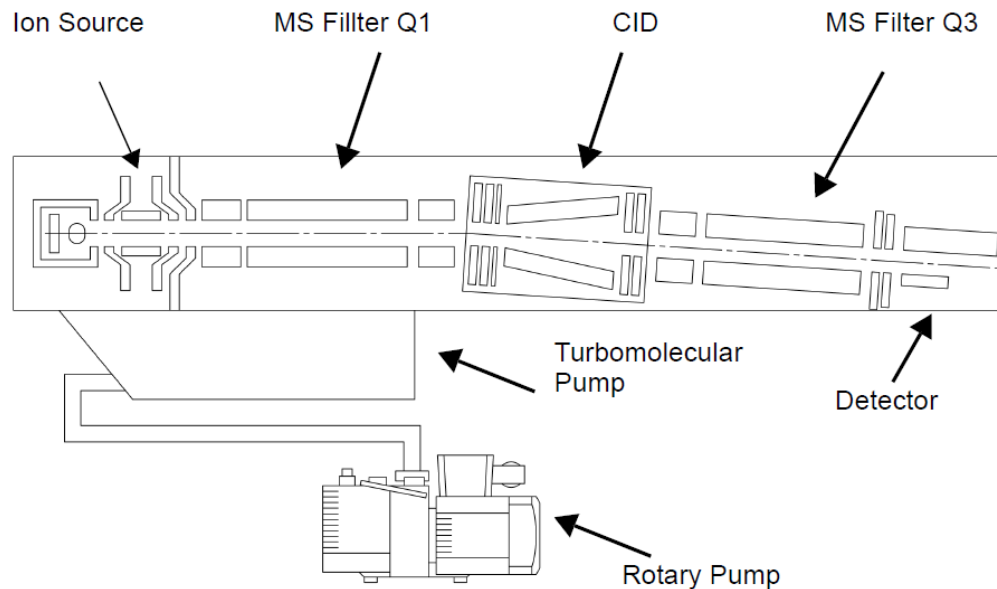
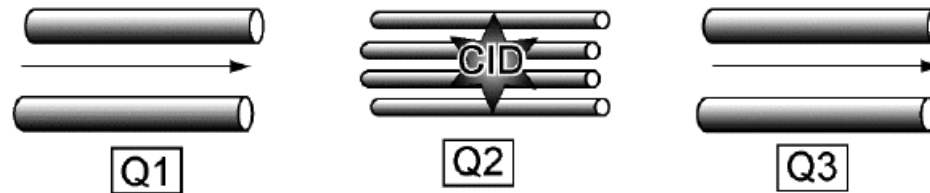

Ütközési cella

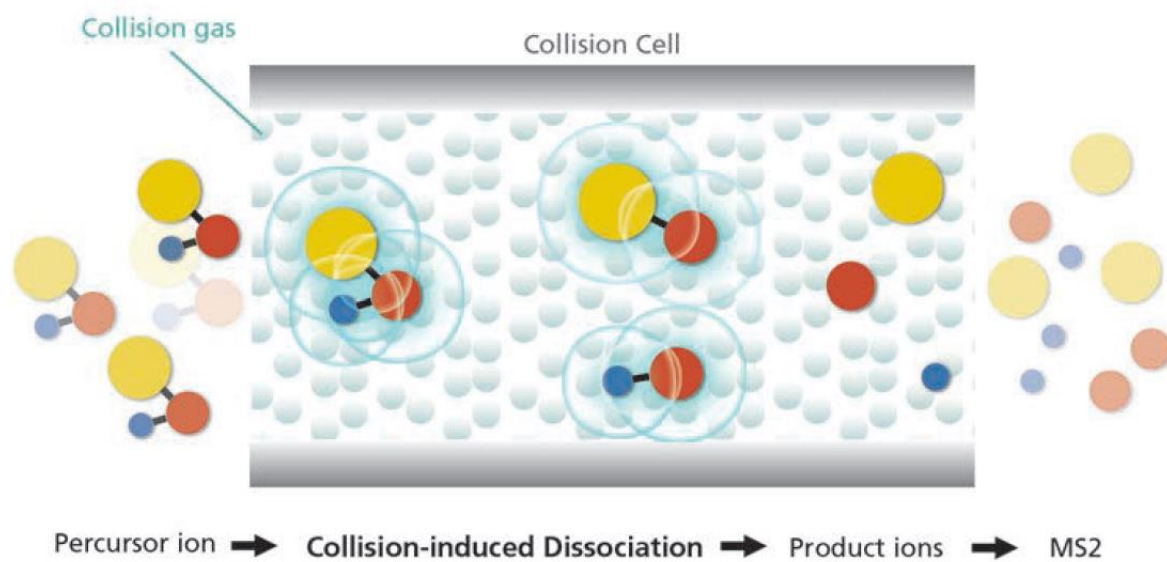
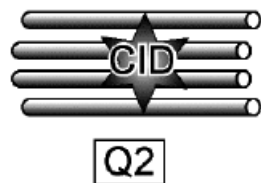

GC-MS/MS rendszerből származó információ

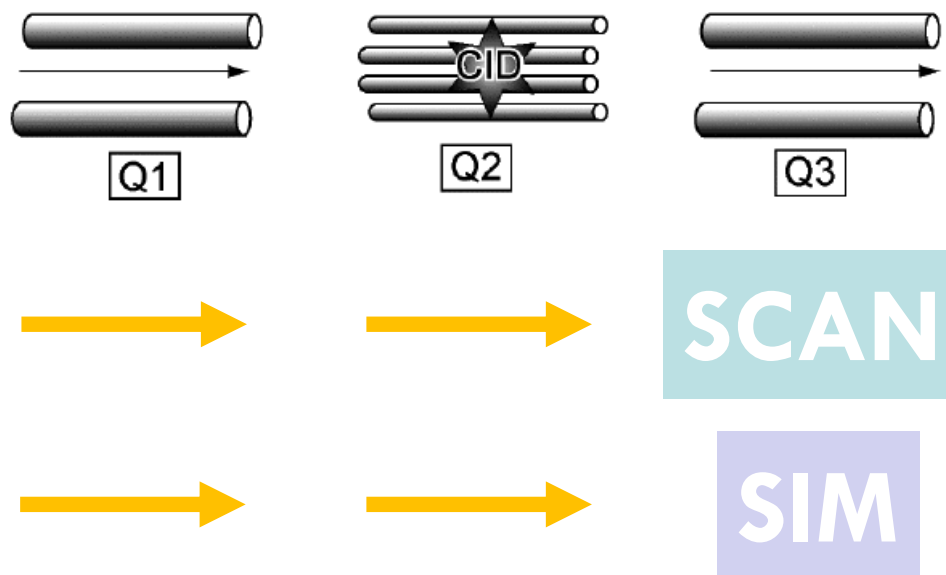

Analysis Mode	Q1	Collision Cell	Q3
Q3 Scan	Transmission mode		Scan
Q3 SIM	Transmission mode		SIM

GC-MS/MS rendszerből származó információ

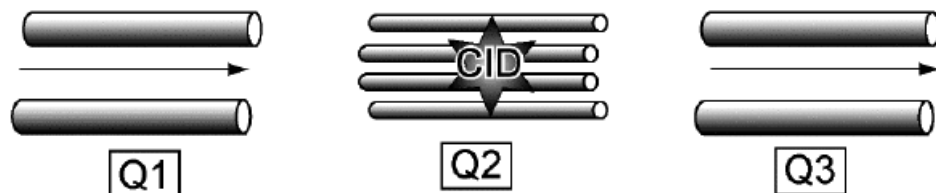

SCAN

SCAN

SIM

SIM

SIM

SCAN

SCAN

SIM

GC-MS/MS rendszerből származó információ

1. Precursor ion scan mode

FAME

McLafferty

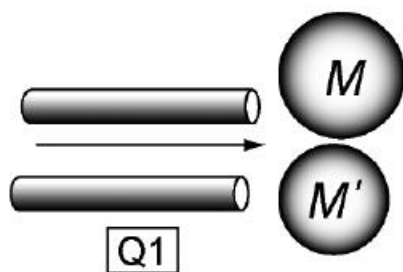
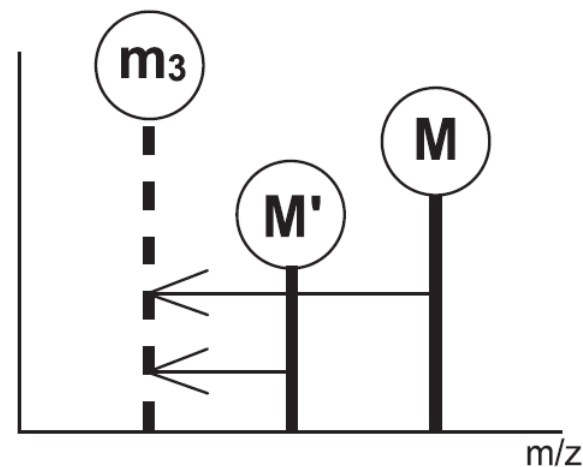
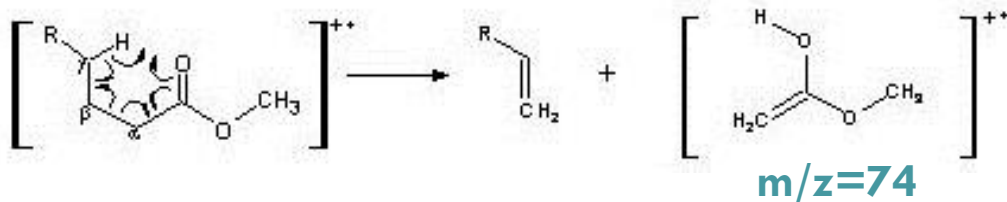

Scanning

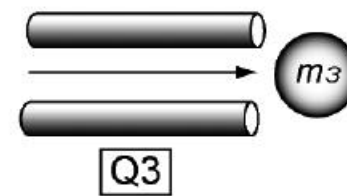
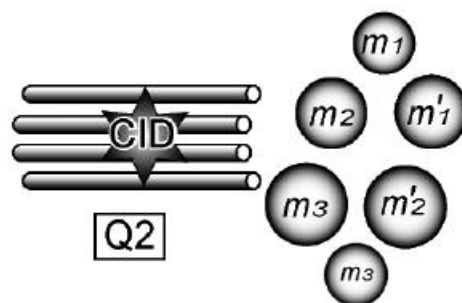

Only m_3 ions pass through

GC-MS/MS rendszerből származó információ

2. Neutral loss

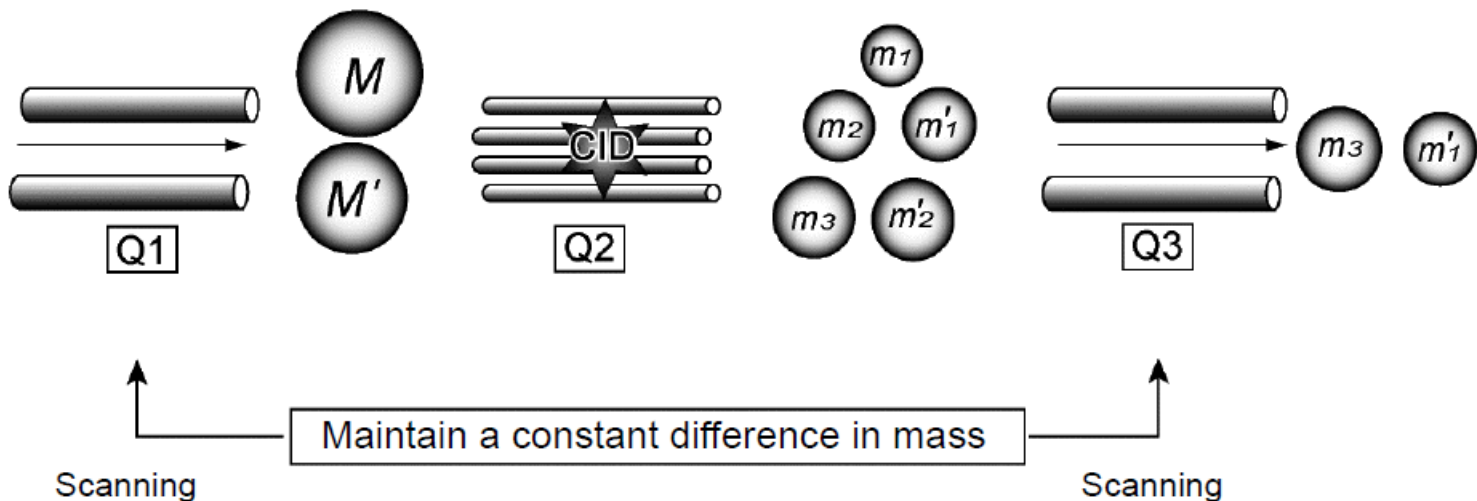
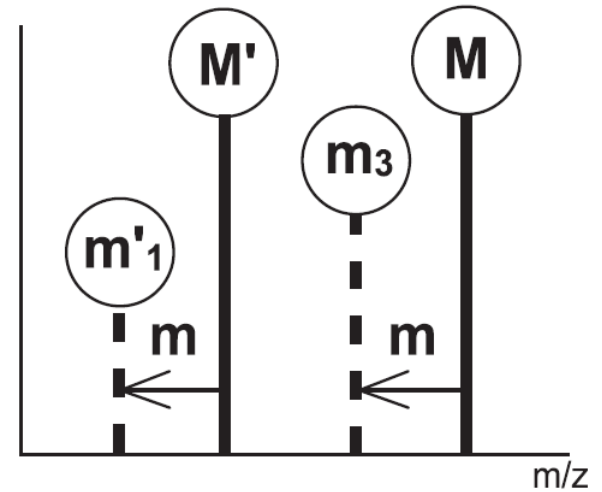

GC-MS/MS rendszerből származó információ

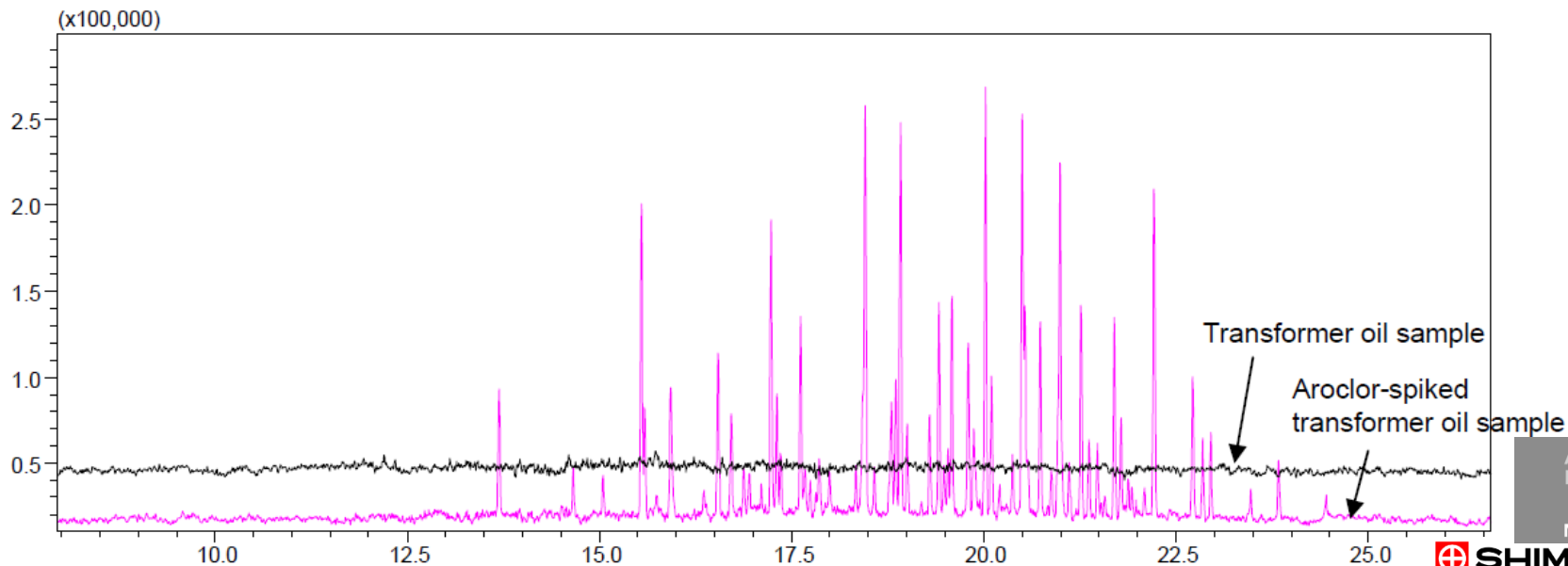
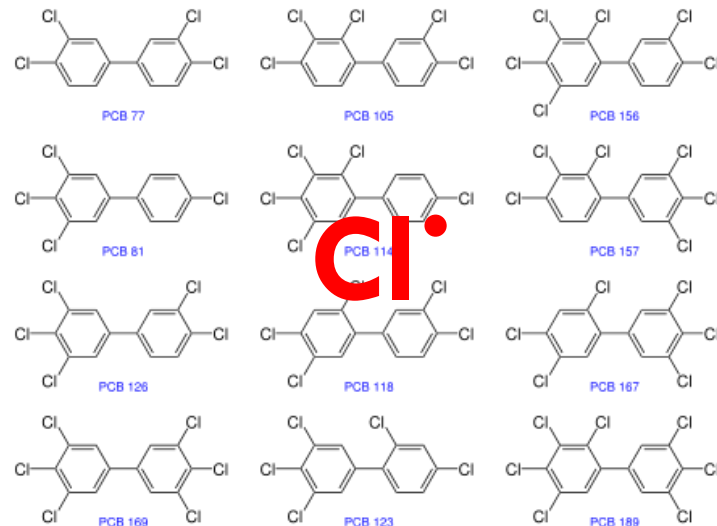
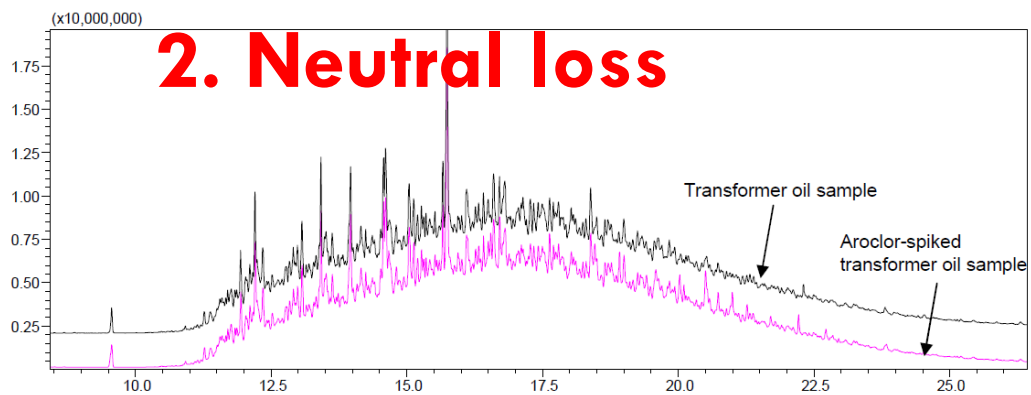

GC-MS/MS rendszerből származó információ

3. Product ion scan

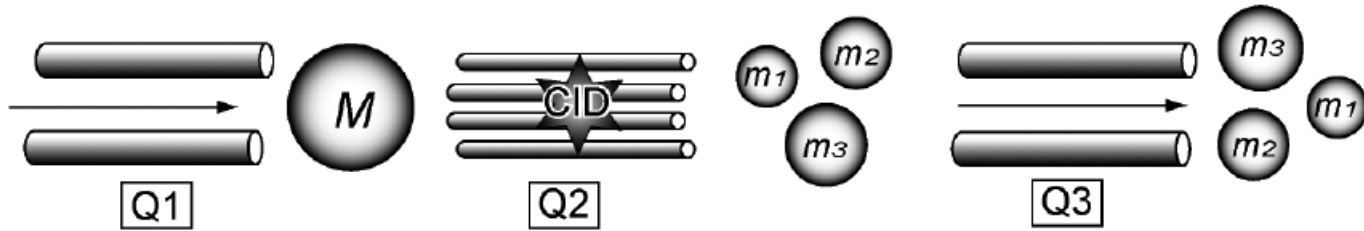
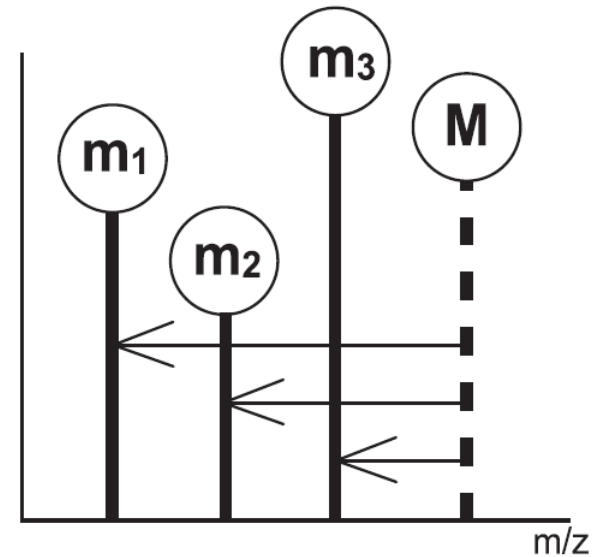

Only M ions pass through

Scanning

GC-MS/MS rendszerből származó információ

3. Product ion scan

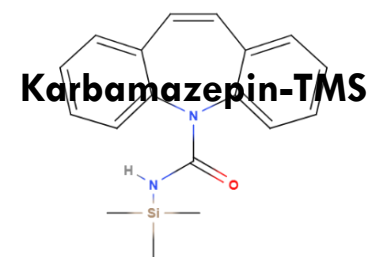
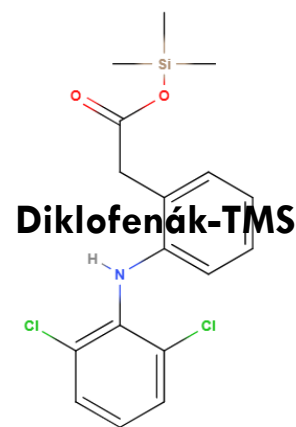
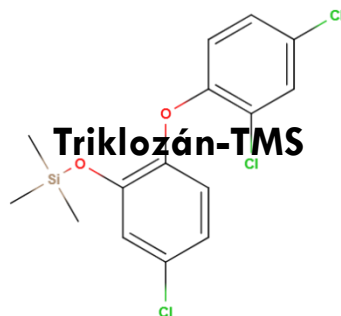
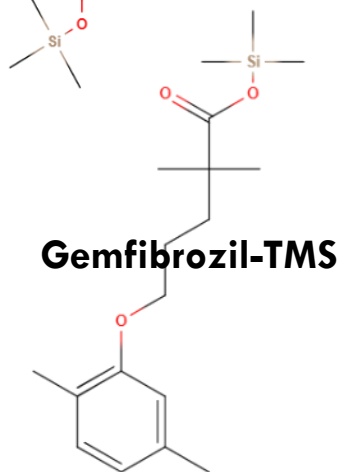
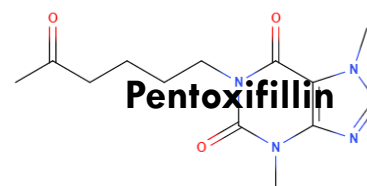
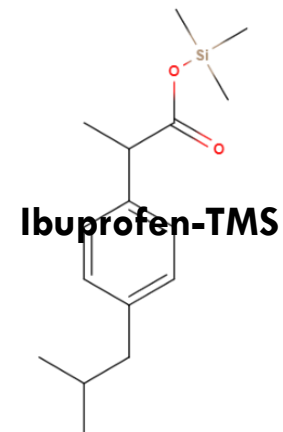
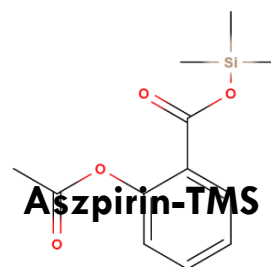
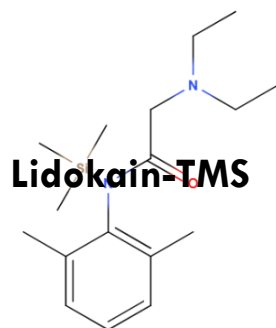
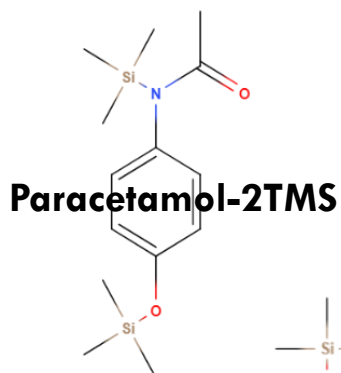

GC-MS/MS rendszerből származó információ

3. Product ion scan

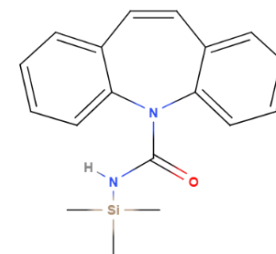
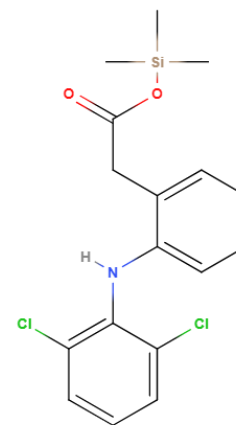
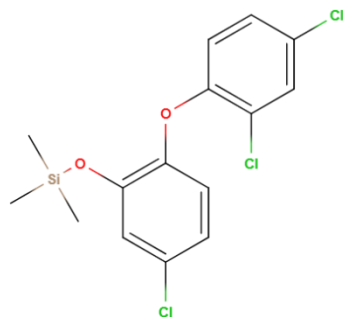
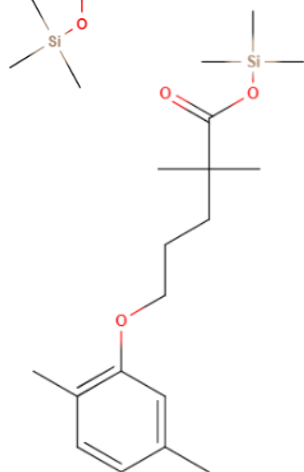
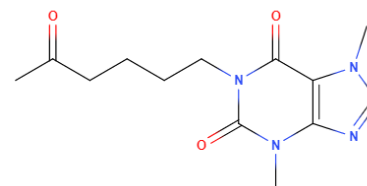
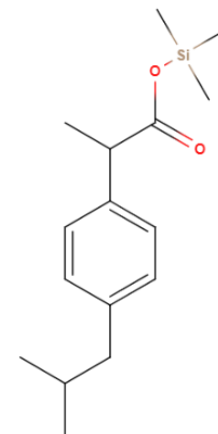
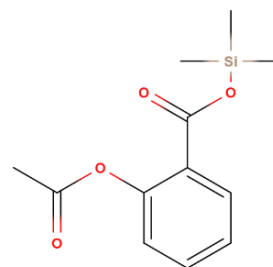
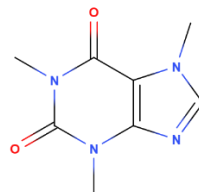
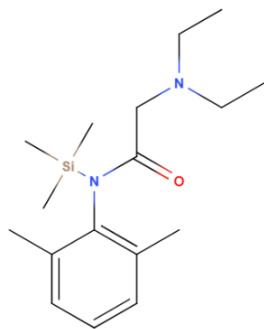
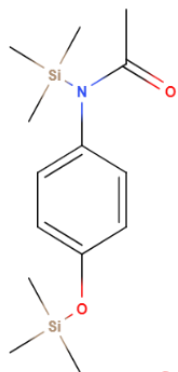

GC-MS/MS rendszerből származó információ

3. Product ion scan

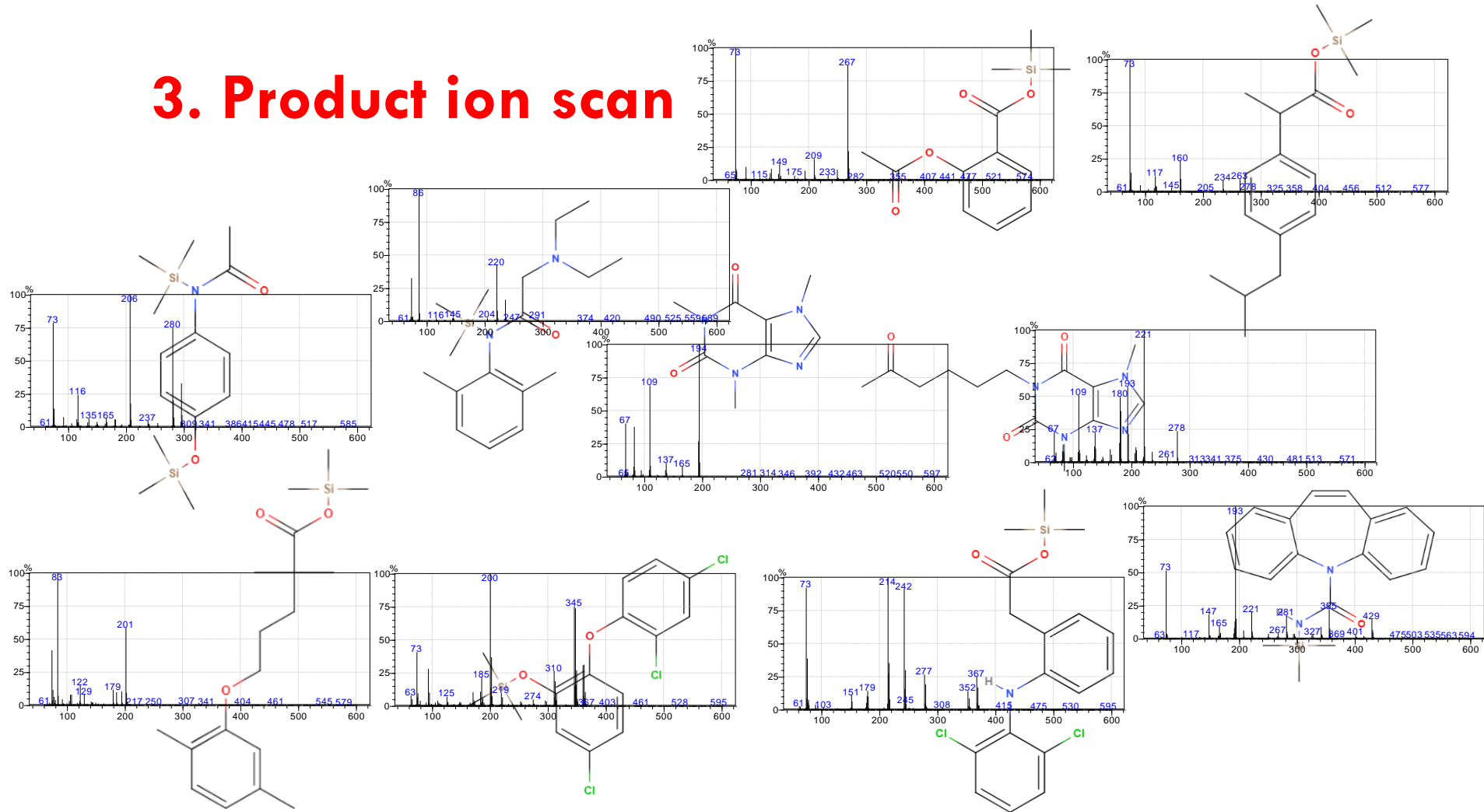

GC-MS/MS rendszerből származó információ

3. Product ion scan

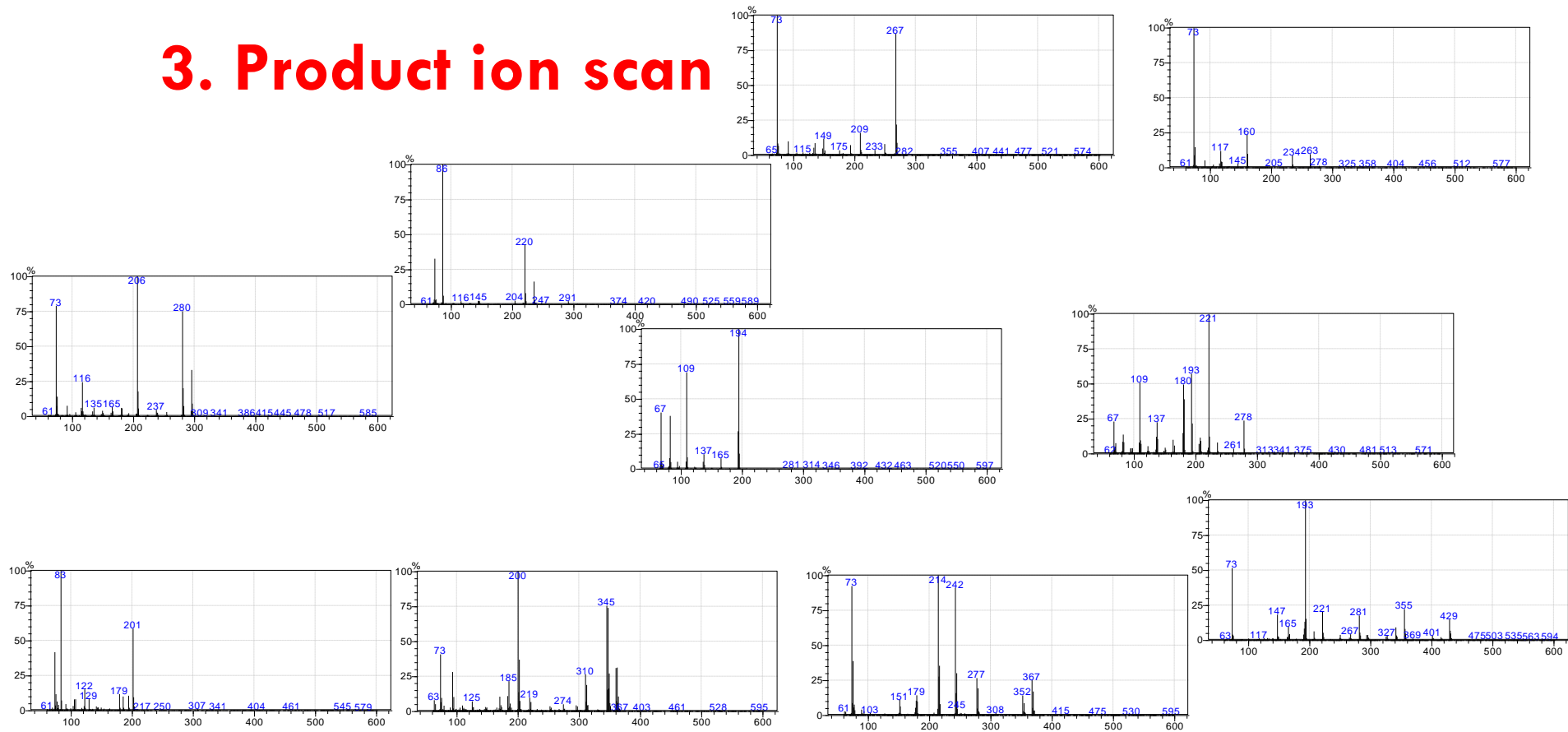

GC-MS/MS rendszerből származó információ

3. Product ion scan

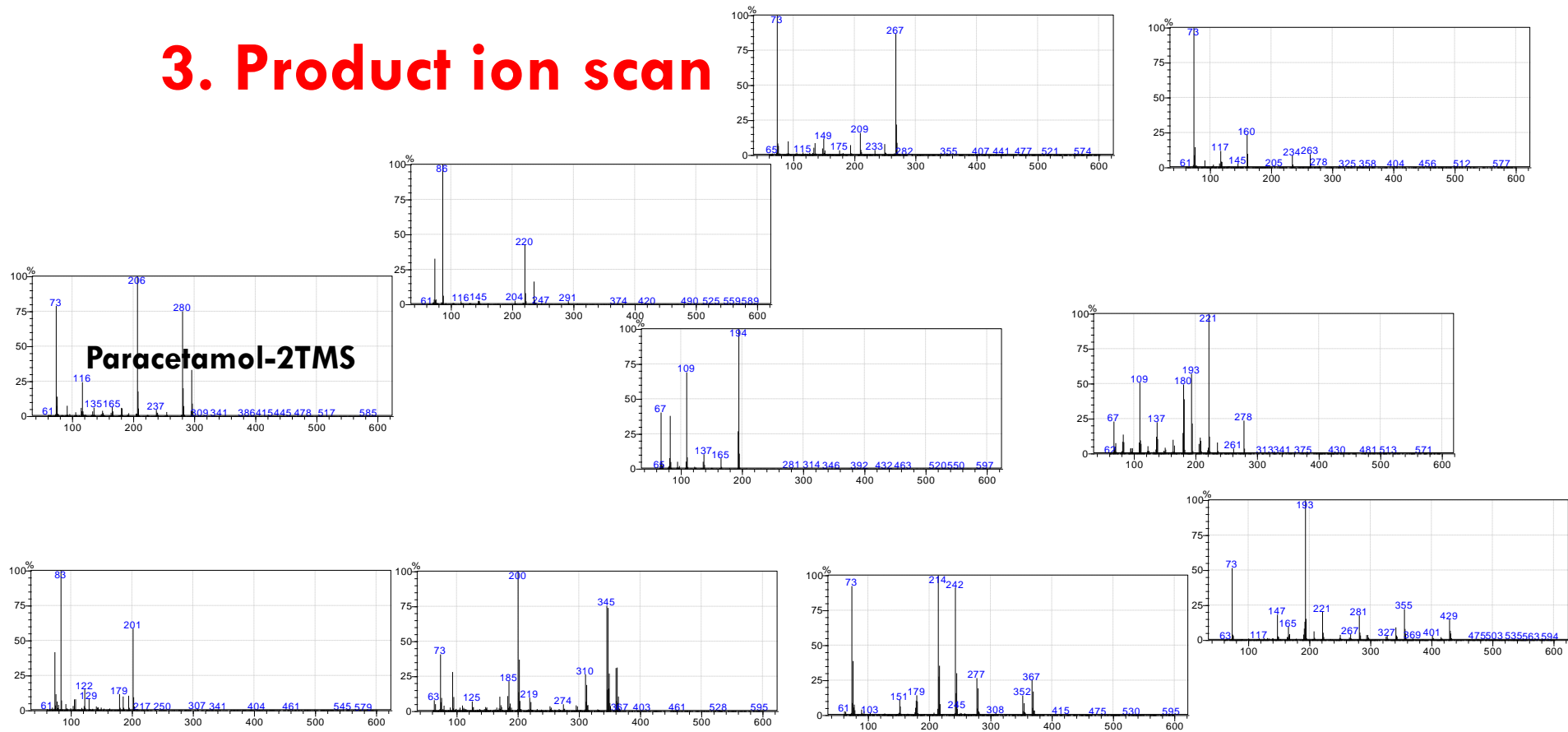

GC-MS/MS rendszerből származó információ

3. Product ion scan

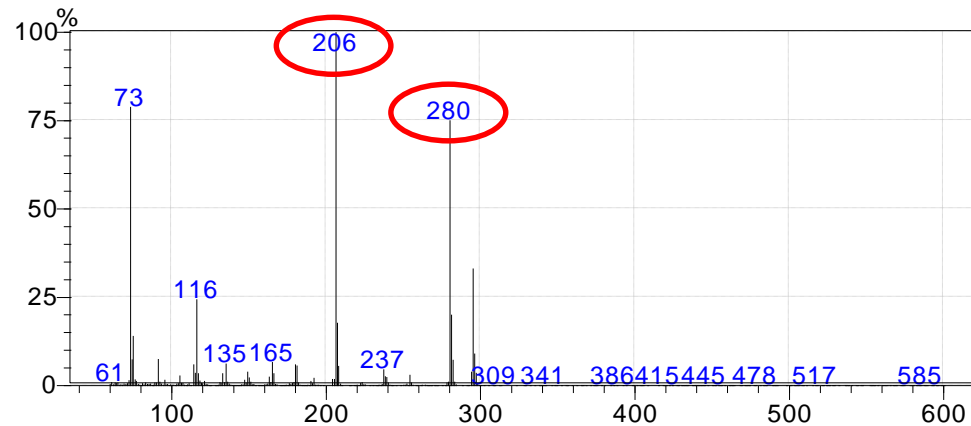

Paracetamol-2TMS

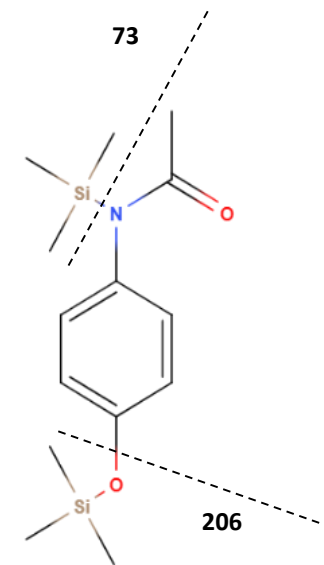

M=295,53 g/mol

GC-MS/MS rendszerből származó információ

3. Product ion scan

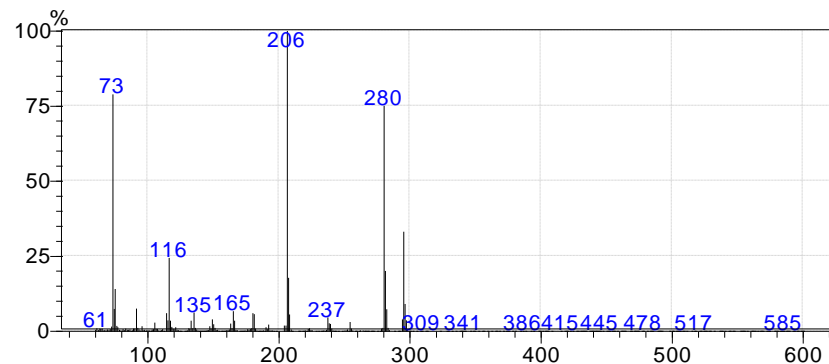
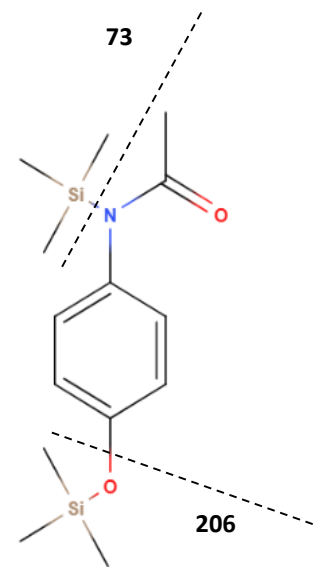
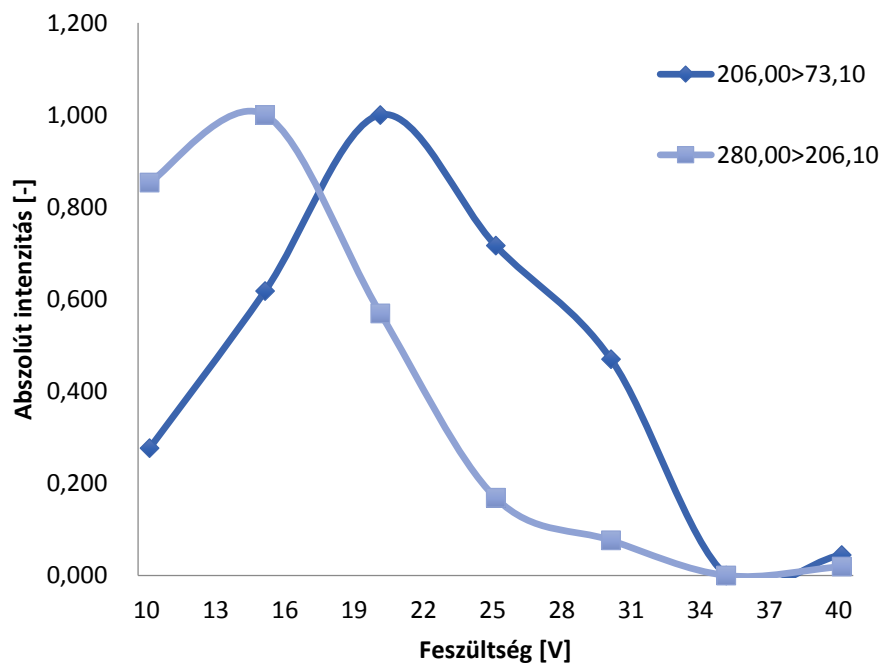

GC-MS/MS rendszerből származó információ

3. Product ion scan

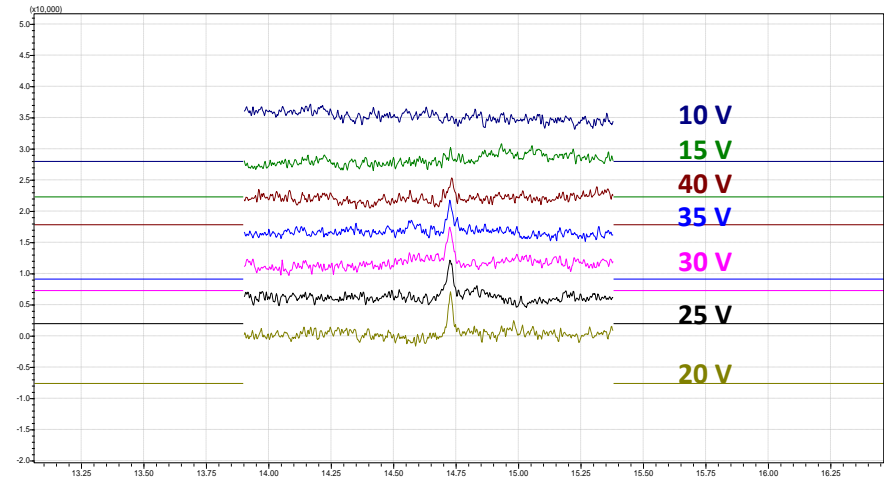
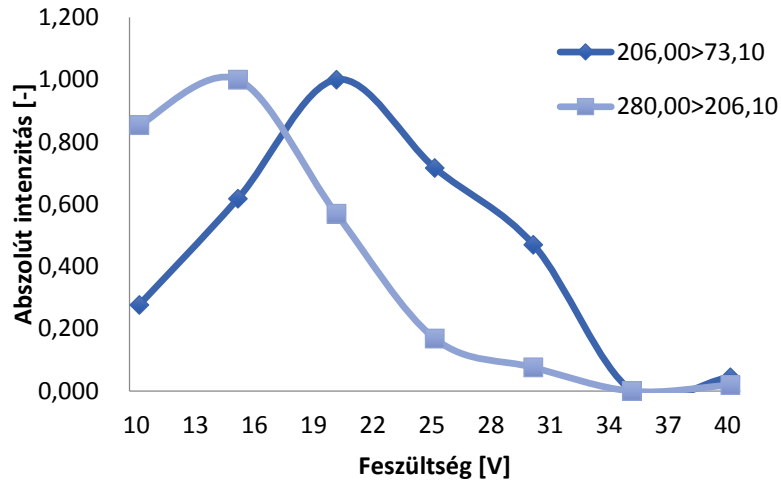

Compound Name	Ret. Index	Ion1				Ion2				Ion3			
		Type	m/z	CE	Ratio	Type	m/z	CE	Ratio	Type	m/z	CE	Ratio
Aszpirin 2 TMS	0	T	267,00>73,10	20	100,00	Ref.1	209,00>91,00	15	13,40	Ref.2	267,00>149,10	10	11,84
Ibuprofen TMS	0	T	160,00>117,10	20	100,00	Ref.1	160,00>145,10	15	40,01	Ref.2	117,00>115,00	15	33,13
Paracetamol 2 TMS	0	T	206,00>73,10	20	100,00	Ref.1	280,00>206,10	15	85,98	Ref.2	206,00>91,10	15	61,88
Lidokain TMS	0	T	86,00>58,10	10	100,00	Ref.1	235,00>220,20	10	60,73	Ref.2	235,00>73,20	20	45,54
Koffein	0	T	194,00>55,00	20	100,00	Ref.1	194,00>109,00	10	79,31	Ref.2	194,00>66,00	40	64,37
Lidokain	0	T	120,00>113,00	20	100,00	Ref.1	120,00>89,00	20	98,98	Ref.2	120,00>69,00	25	95,92
Gemfibrozil TMS	0	T	201,00>83,20	10	100,00	Ref.1	201,00>55,10	25	84,40	Ref.2	201,00>73,10	25	26,31
Indol-3-propionsav TMS	0	T	202,00>73,10	20	100,00	Ref.1	333,00>73,20	30	24,12	Ref.2	333,00>202,20	15	12,33
Triklozan TMS	0	T	200,00>169,90	30	100,00	Ref.1	200,00>185,00	20	82,75	Ref.2	347,00>185,00	30	19,80
Karbamazepin TMS	0	T	193,00>165,10	25	100,00	Ref.1	193,00>191,10	30	96,21	Ref.2	193,00>167,10	15	65,98
Diklofenak TMS	0	T	214,00>179,00	25	100,00	Ref.1	214,00>151,00	25	78,89	Ref.2	214,00>177,00	40	71,75
Pentoxifillin	0	T	221,00>73,00	20	100,00	Ref.1	221,00>176,00	20	57,78	Ref.2	221,00>95,00	20	59,56

GC-MS/MS rendszerből származó információ

4. MRM (Multiple Reaction Monitoring)

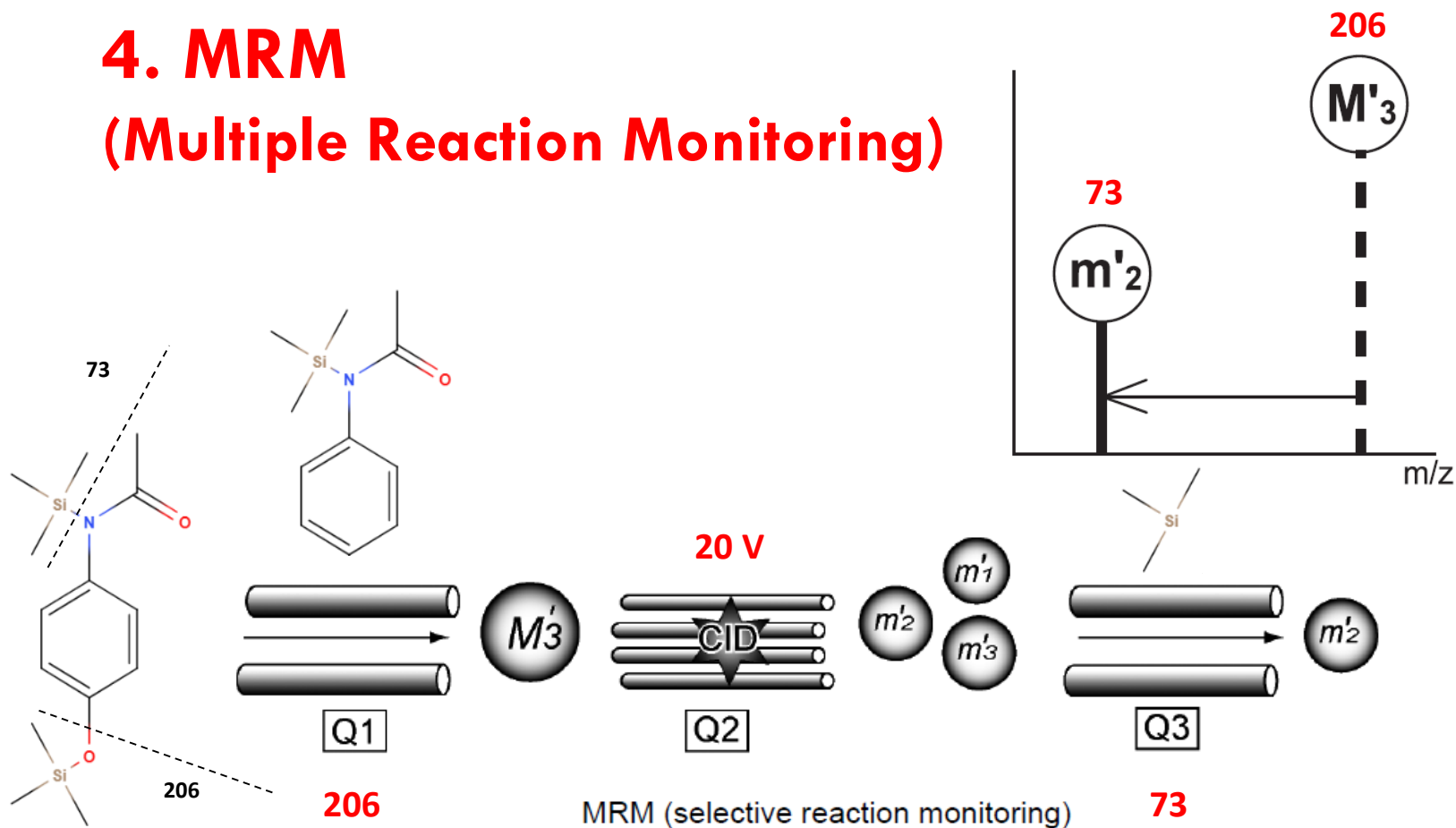

GC-MS/MS rendszerből származó információ

4. MRM (Multiple Reaction Monitoring)

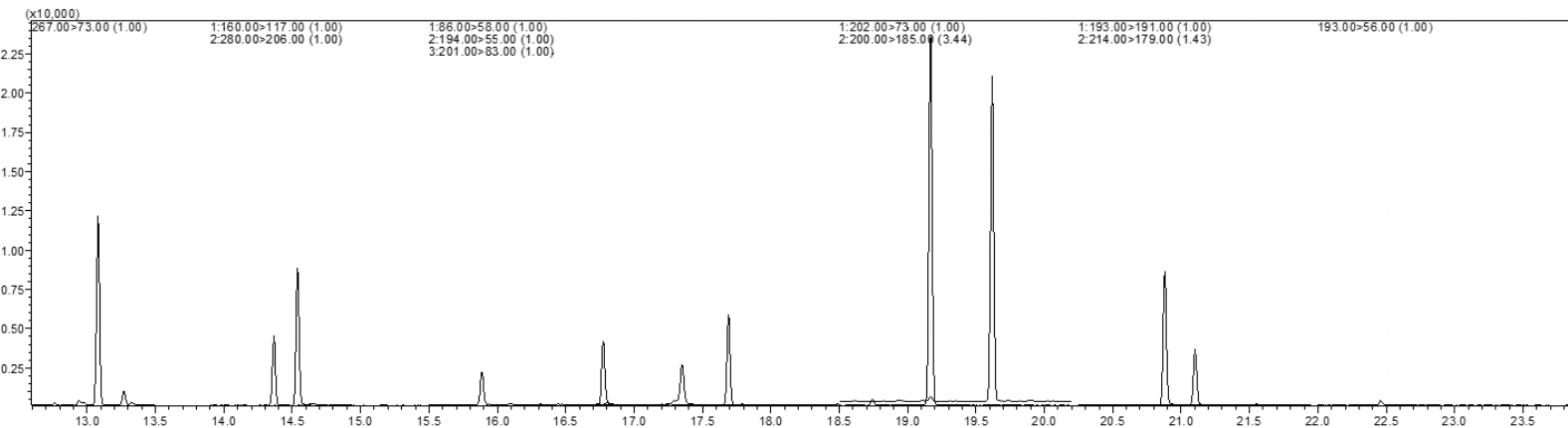
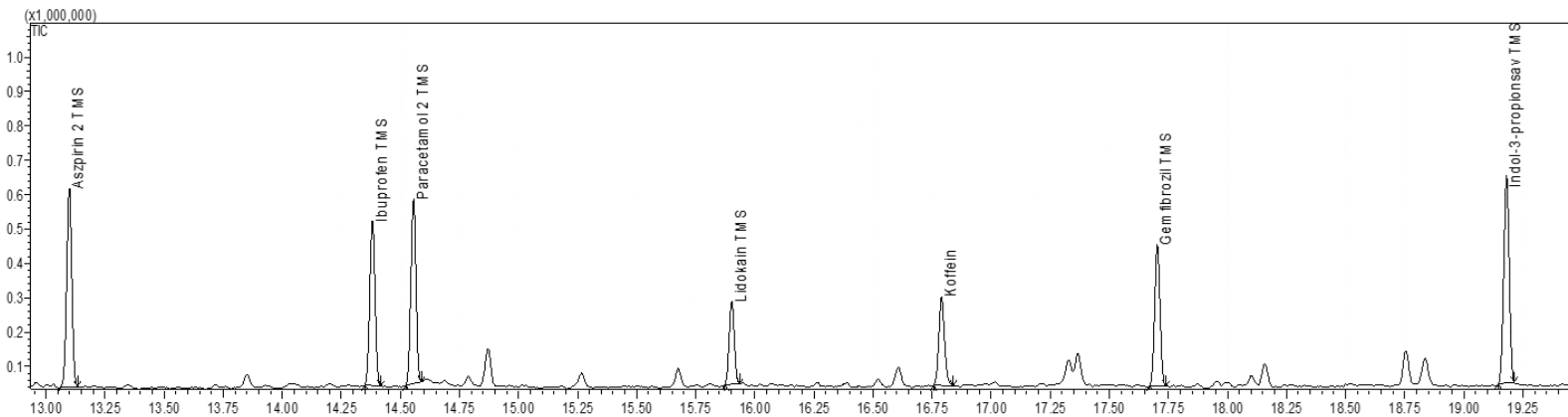

GC-MS/MS rendszerből származó információ

Analysis Mode	Q1	Collision Cell	Q3
Q3 Scan	Transmission mode		Scan
Q3 SIM	Transmission mode		SIM

Analysis Mode	Q1	Collision Cell	Q3
Precursor Ion Scan	Scan	CID	SIM
Product Ion Scan	SIM		Scan
Neutral Loss Scan	Scan		Scan
MRM	SIM		SIM

Bűzforrás

Adszorpciós mintavétel

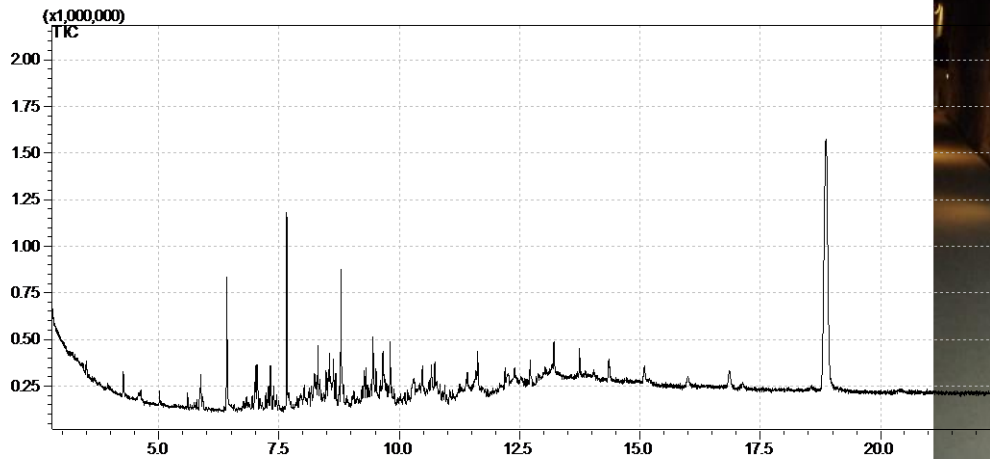

Permanens gázok elemzése

Barlangi levegő összetételének meghatározása



Permanens gázok elemzése

Barlangi levegő összetételének meghatározása

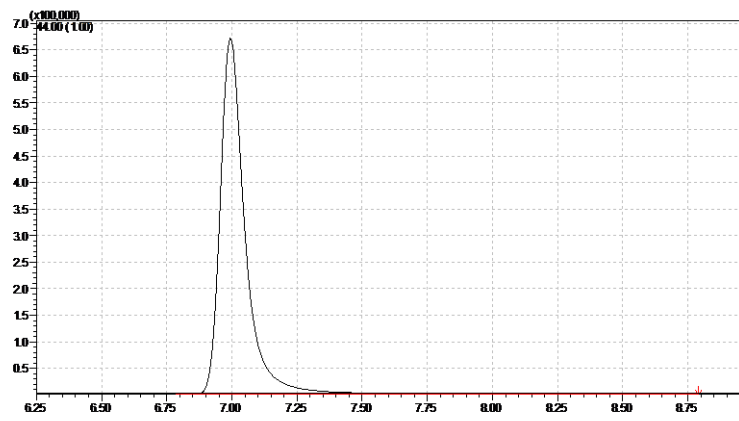
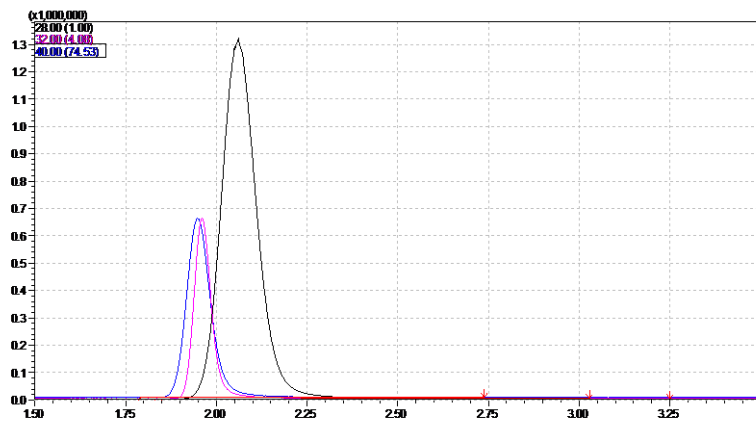

Data Acquisition Parameters

GC MS Description

Inj. Port : SPL1 Inj. Heat Port : INJ1

Column Oven Temp. : 35.0 °C

Injection Temp. : 220.0 °C

Injection Mode : Split

Sampling Time : 1.00 min

Carrier Gas : He Prim. Press. : 500-900

Flow Control Mode : Linear Velocity

Pressure : 90.2 kPa

Total Flow : 117.4 mL/min

Column Flow : 4.48 mL/min

Linear Velocity : 76.1 cm/sec

Purge Flow : 1.0 mL/min

Split Ratio : 25.0

Program : Column Oven Temperature

	Rate	Final Temperature	Hold Time
0	-	35.0	3.00
1	50.00	100.0	4.70
2	0.00	0.0	0.00
3	0.00	0.0	0.00

Total Program Time : 9.00 min

Column Name : Carboxen 1010 Thickness : 0.00 um Length : 30.0 m Diameter : 0.32 mm

Data Acquisition Parameters

GC MS Description

GCMS-QP2010

Ion Source Temp. : 200 °C

Interface Temp. : 200 °C

Solvent Cut Time : 0 min

Micro Scan Width : 0 u

Detector Voltage : Relative to the Tuning Result Absolute

GC Program Time : 9.00 min

Group#1 - Event#1

	Start Time (min)	End Time (min)	Acq. Mode	Event Time(sec)	Scan Speed	S	E	Ch1 m/z	Ch2 m/z	Ch3 m/z	Ch4 m/z
1	1.50	3.50	SIM	0.10				28.00	32.00	40.00	0.00
2	4.00	5.50	SIM	0.10				16.00	0.00	0.00	0.00
3	6.25	9.00	SIM	0.10				44.00	0.00	0.00	0.00
4	0.00	0.00	Scan	0.00	0	0	0				

Policiklusos aromás vegyületek (PAH-ok) meghatározása

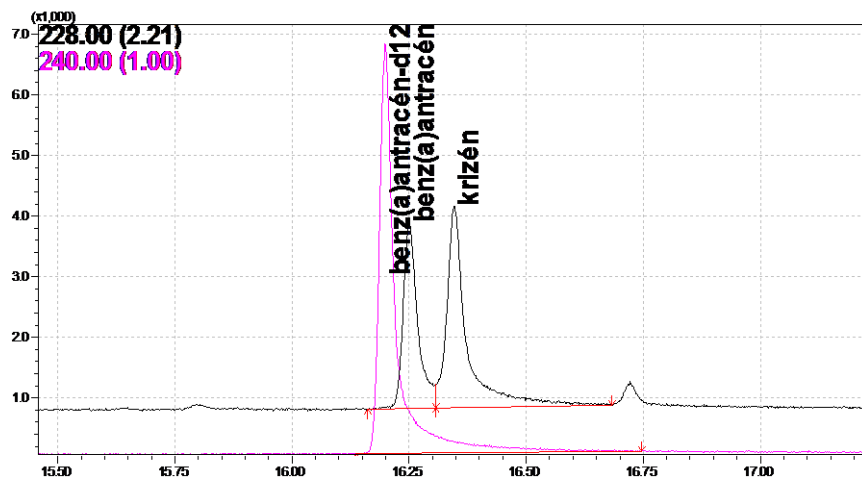

ng/ml !

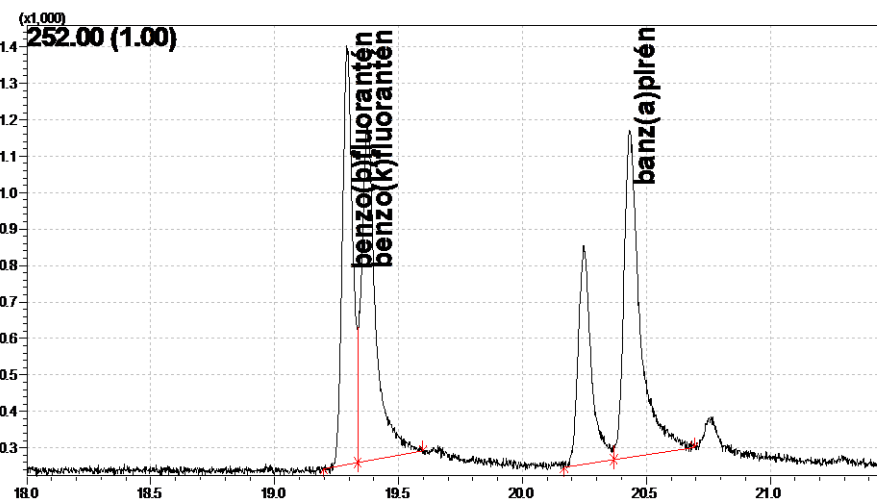

Transzformátorolaj

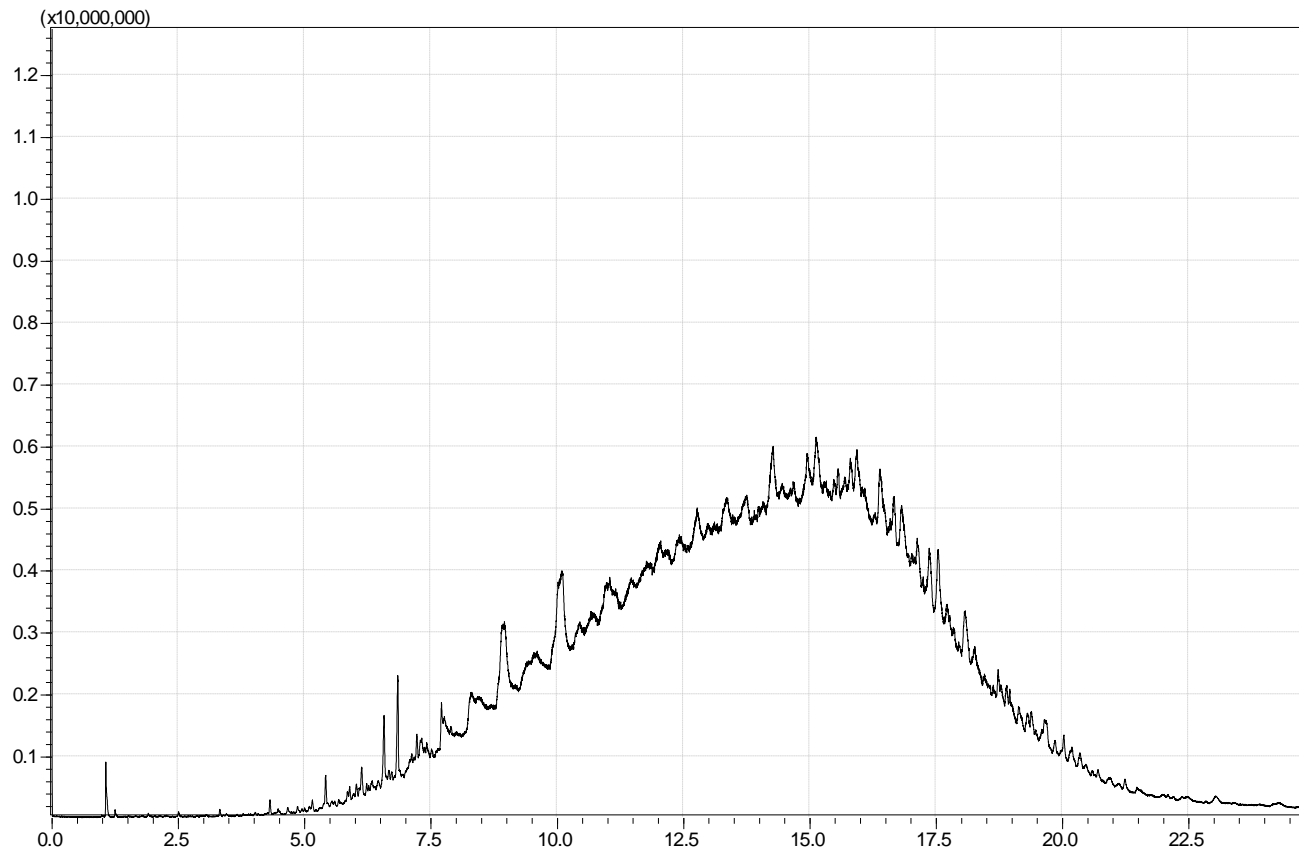

Transzformátorolaj

DBDS (dibenzil-diszulfid) tartalom meghatározása

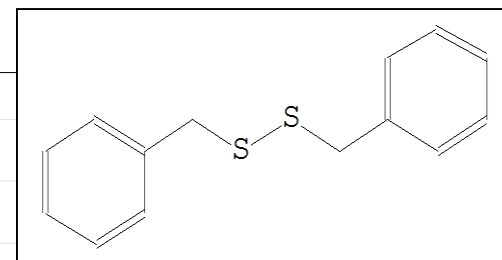
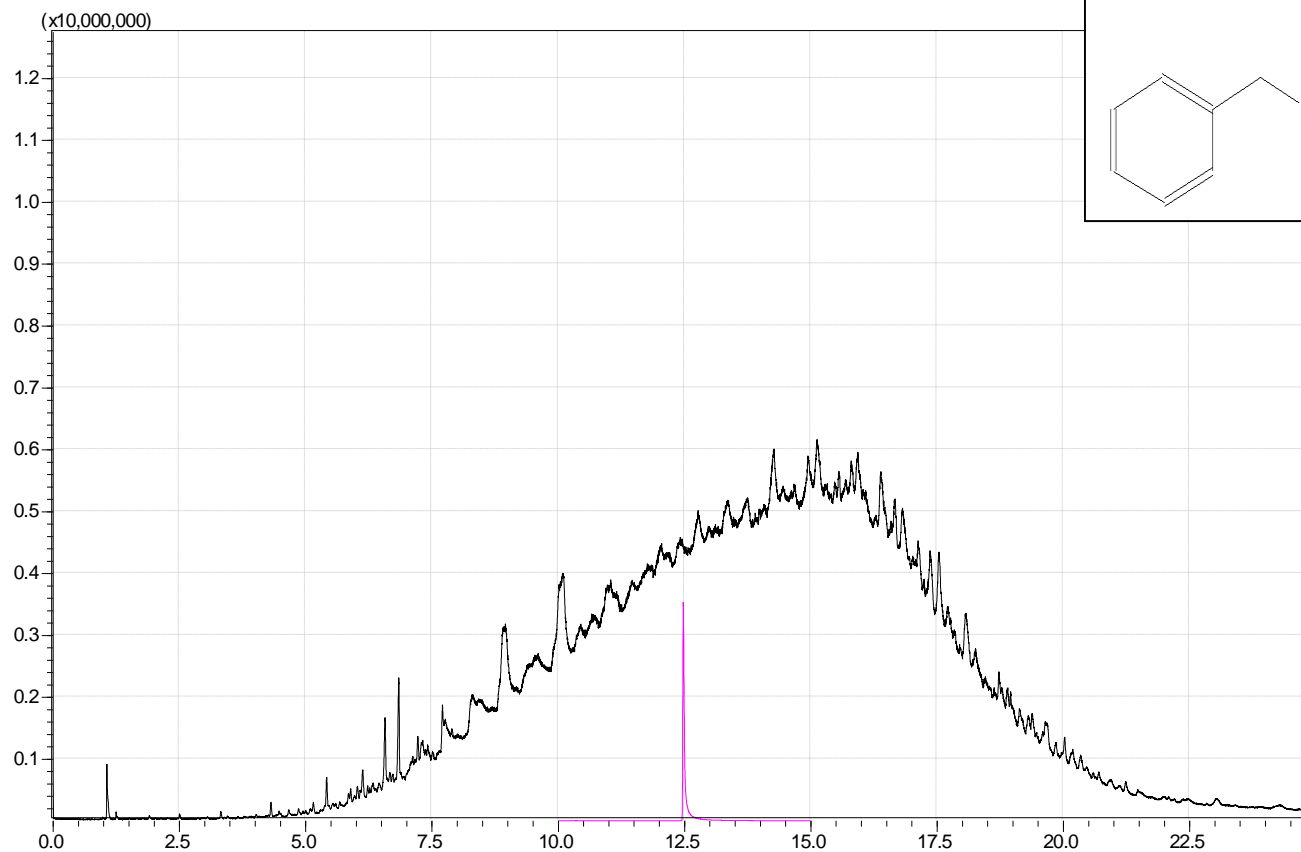

Transzformátorolaj

DBDS (dibenzil-diszulfid) tartalom meghatározása

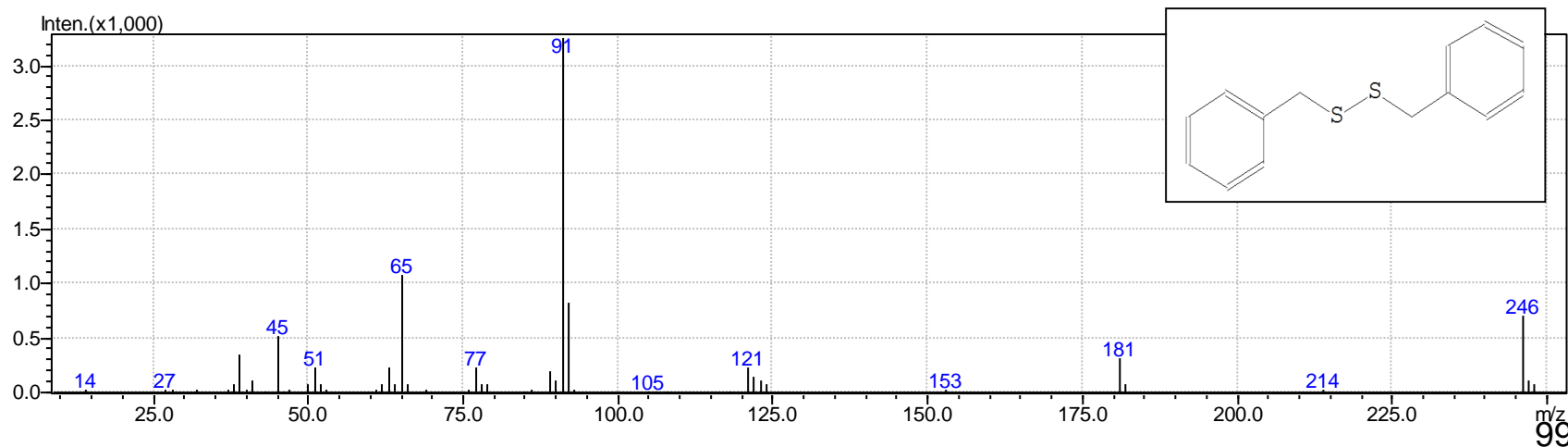
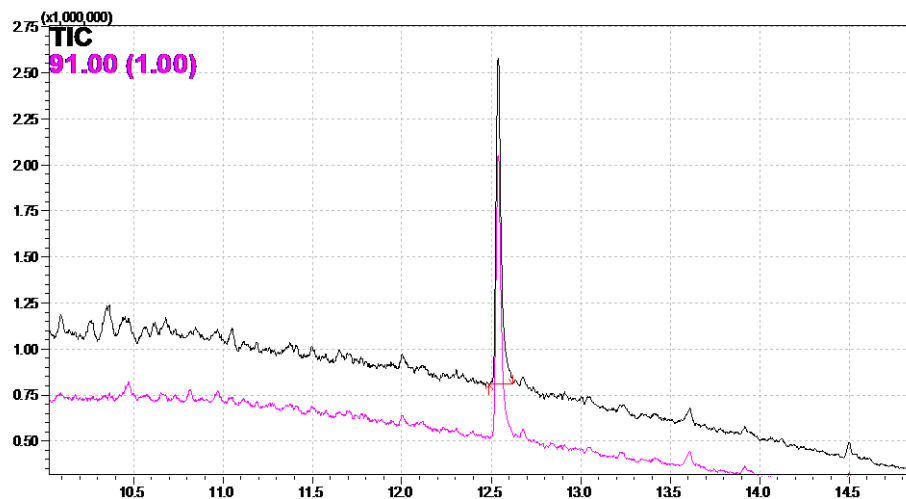

Klórbenzolak mérése felszín alatti vizekből

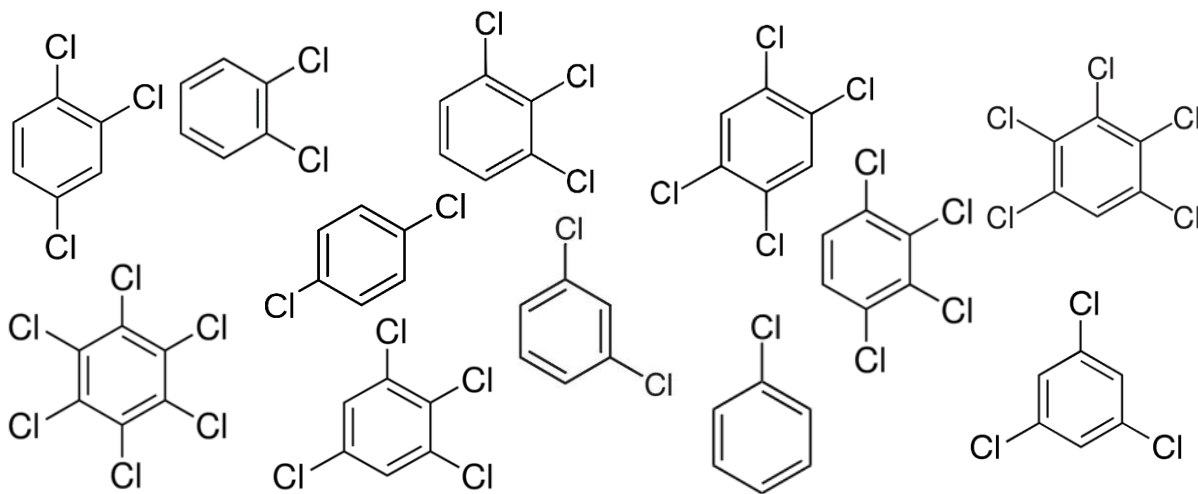
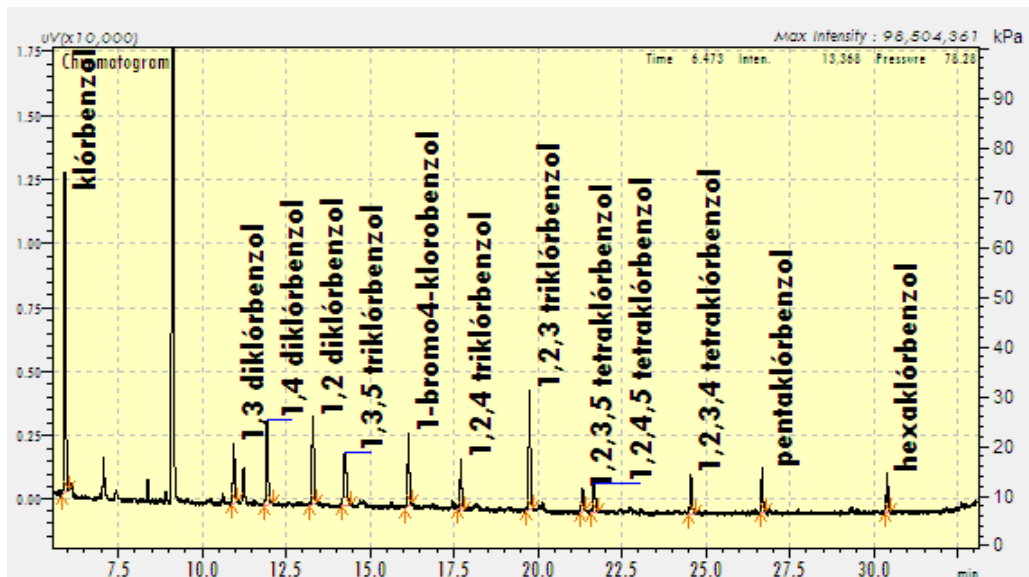
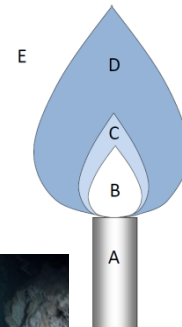

Komponens	t_R
klórbenzol	5.947
1,3-diklórbenzol	10.989
1,4-diklórbenzol	11.981
1,2-diklórbenzol	13.347
1,3,5-triklórbenzol	14.298
1-bróm-4-klórbenzol	16.188
1,2,4-triklórbenzol	17.742
1,2,3-triklórbenzol	19.793
1,2,3,5-tetraklórbenzol	21.380
1,2,4,5-tetraklórbenzol	21.728
1,2,3,4-tetraklórbenzol	24.600
pentaklórbenzol	26.714
hexaklórbenzol	30.455

Klórbenzolok mérése felszín alatti vizekből

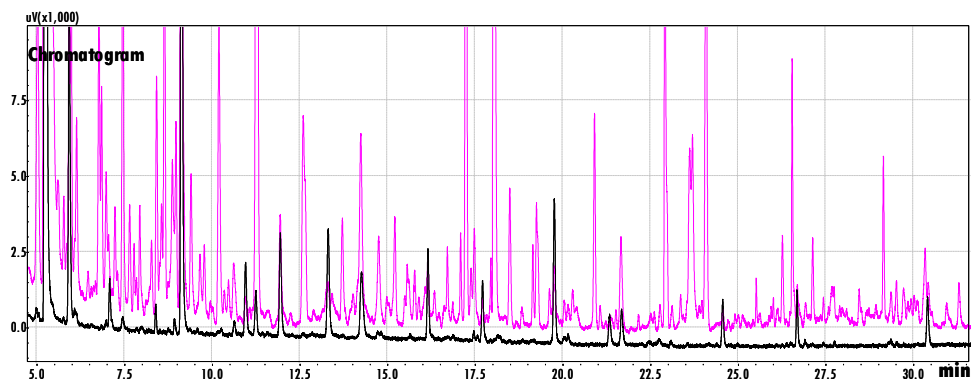
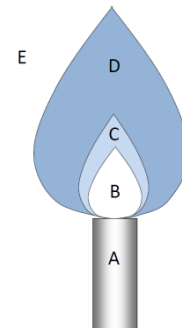

minta

standard

Klórbenzolak mérése felszín alatti vizekből

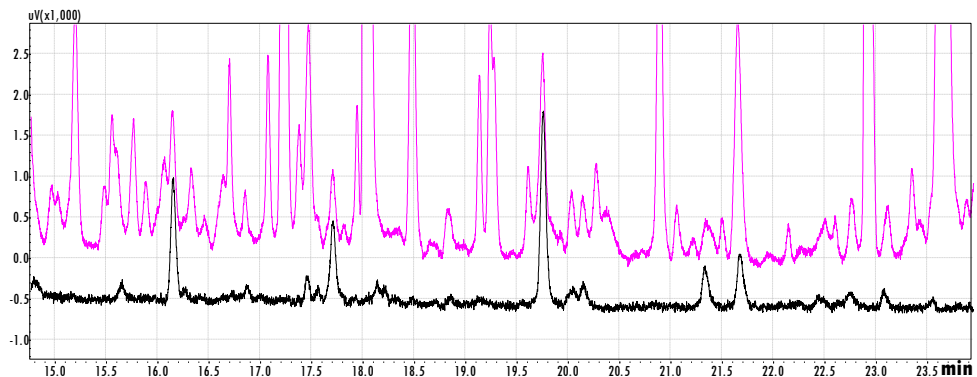
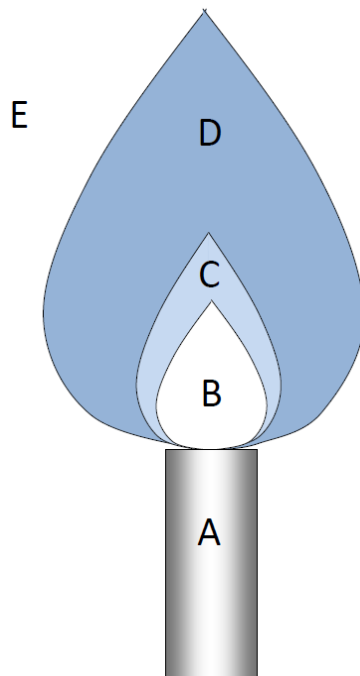

Klórbenzolok mérése felszín alatti vizekből

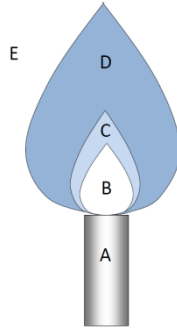
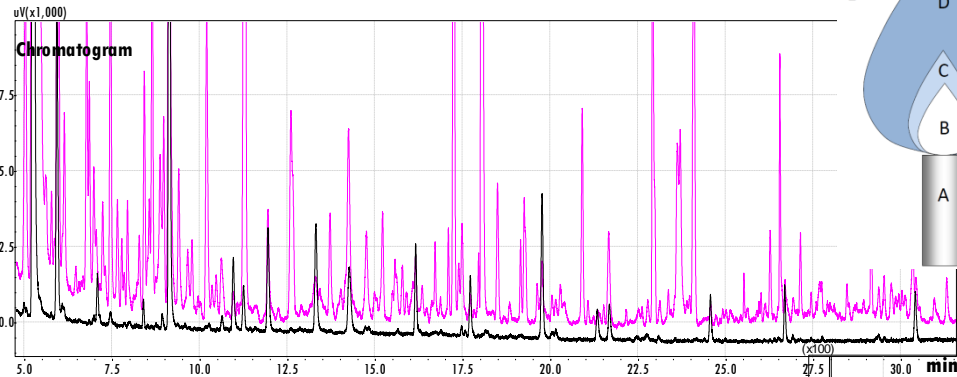

	Detektálás kezdete (min)	Detektálás vége (min)	m/z
Klórbenzol	5,3	7,25	112
1,3-diklórbenzol	10,3	11,65	146
1,4-diklórbenzol	11,7	12,9	146
1,2-diklórbenzol	13	14,08	146
1,3,5-triklórbenzol	14,1	15,15	182
1-bróm-4-klórbenzol	15,75	17	192
1,2,4-triklórbenzol	17,25	18,25	180
1,2,3-triklórbenzol	19,25	20,5	180
1,2,3,5 és 1,2,4,5-tetraklórbenzol	20,75	22,5	216
1,2,3,4-tetraklórbenzol	24	25,25	216
Pentaklórbenzol	26,25	27,25	250
Hexaklórbenzol	30	31,2	284

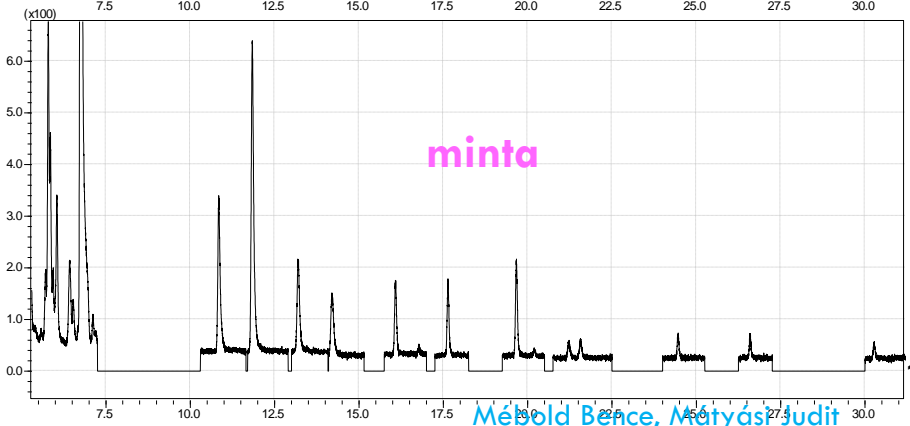
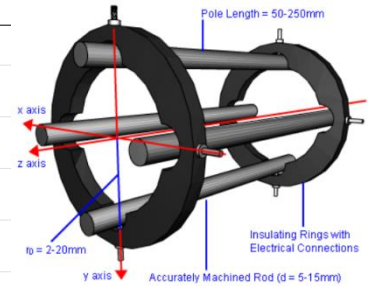
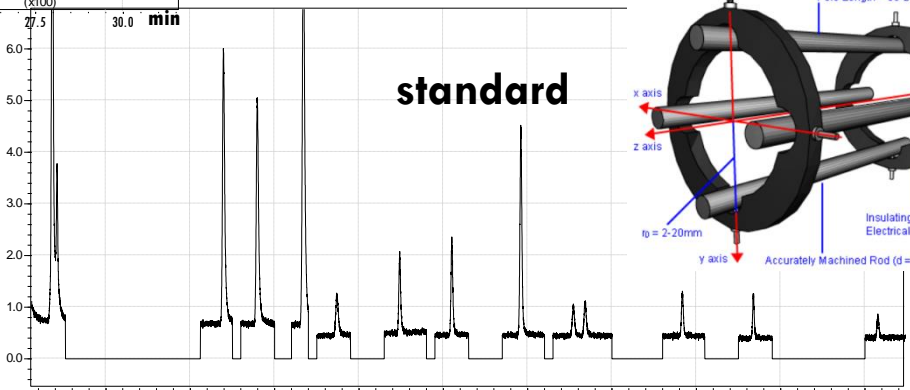

Xilolok

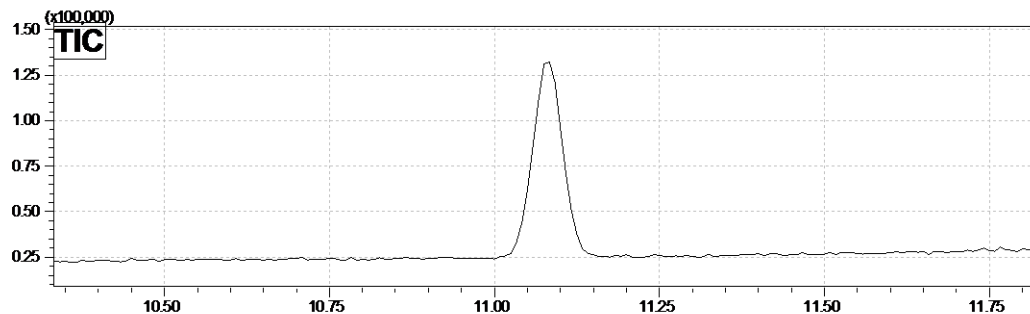

Similarity Search Results

Report View Compound Info Process Help

Hit#	Simila	Regi	Compound Name	Mol Wt	Formula	Library
1	97	71	p-Xylene \$\$ Benzene, 1,4-dimethyl- \$\$ p-Dim	106	C8H10	NIST05s.LIB
2	97	71	o-Xylene \$\$ Benzene, 1,2-dimethyl- \$\$ o-Dim	106	C8H10	NIST05s.LIB
3	96	71	Benzene, 1,3-dimethyl- \$\$ m-Xylene \$\$ m-Di	106	C8H10	NIST05s.LIB
4	96	71	p-Xylene \$\$ Benzene, 1,4-dimethyl- \$\$ p-Di	106	C8H10	NIST05s.LIB
5	95	71	p-Xylene \$\$ Benzene, 1,4-dimethyl- \$\$ p-Dim	106	C8H10	NIST05s.LIB
6	95	71	o-Xylene \$\$ Benzene, 1,2-dimethyl- \$\$ o-Dim	106	C8H10	NIST05s.LIB
7	95	71	o-Xylene \$\$ Benzene, 1,2-dimethyl- \$\$ o-Dim	106	C8H10	NIST05s.LIB
8	94	71	p-Xylene \$\$ Benzene, 1,4-dimethyl- \$\$ p-Dim	106	C8H10	NIST05s.LIB

Target:

1: 106: p-Xylene \$\$ Benzene, 1,4-dimethyl- \$\$ p-Dimethylbenzene \$\$ p-Xylol \$\$ 1,4-Dimethylbenzene \$\$ 1,4-Xylene \$\$ p-Methyltoluene \$\$ para-Xylene \$\$ Chromar \$\$ Scintillar \$\$ UN 1307 \$\$ 4-Methyltoluene \$\$ 1,4-Dimethyl benzene \$\$

CAS#: 106-42-3 Mol Wt: 106 Serial#: 2335

Cmpd Name: p-Xylene \$\$ Benzene, 1,4-dimethyl- \$\$ p-Dimethylbenzene \$\$ p-Xylol \$\$ 1,4-Dimethylbenzene \$\$ 1,4-Xylene \$\$ p-Methyltoluene \$\$ para-Xylene \$\$ Chromar \$\$ Scintillar \$\$ UN 1307 \$\$ 4-Methyltoluene \$\$ 1,4-Dimethyl benzene \$\$

Formula: C8H10 Class Flag: No Class Flags

Ret.Index: 907

HU 20:05 2019.02.25

Xilolok

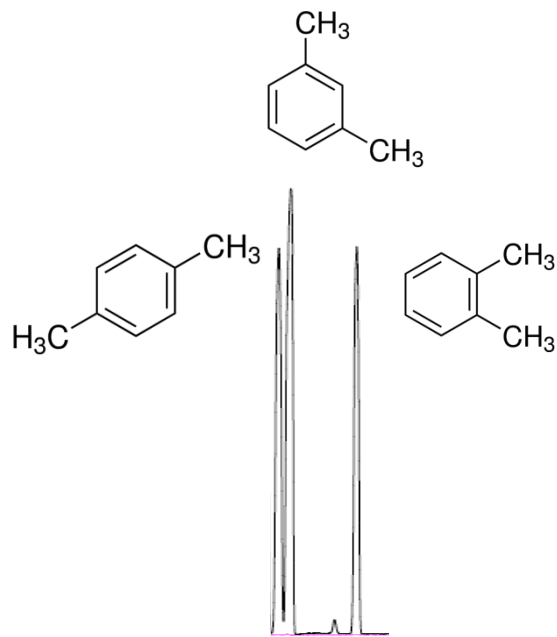
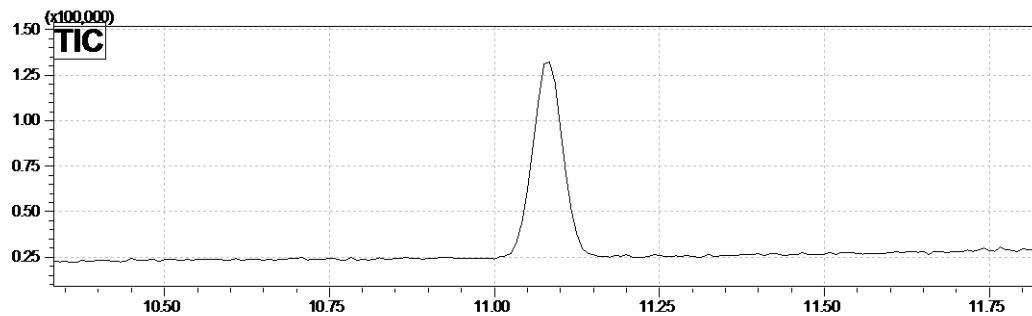

Minőségi analízis
retenciós idő alapján!

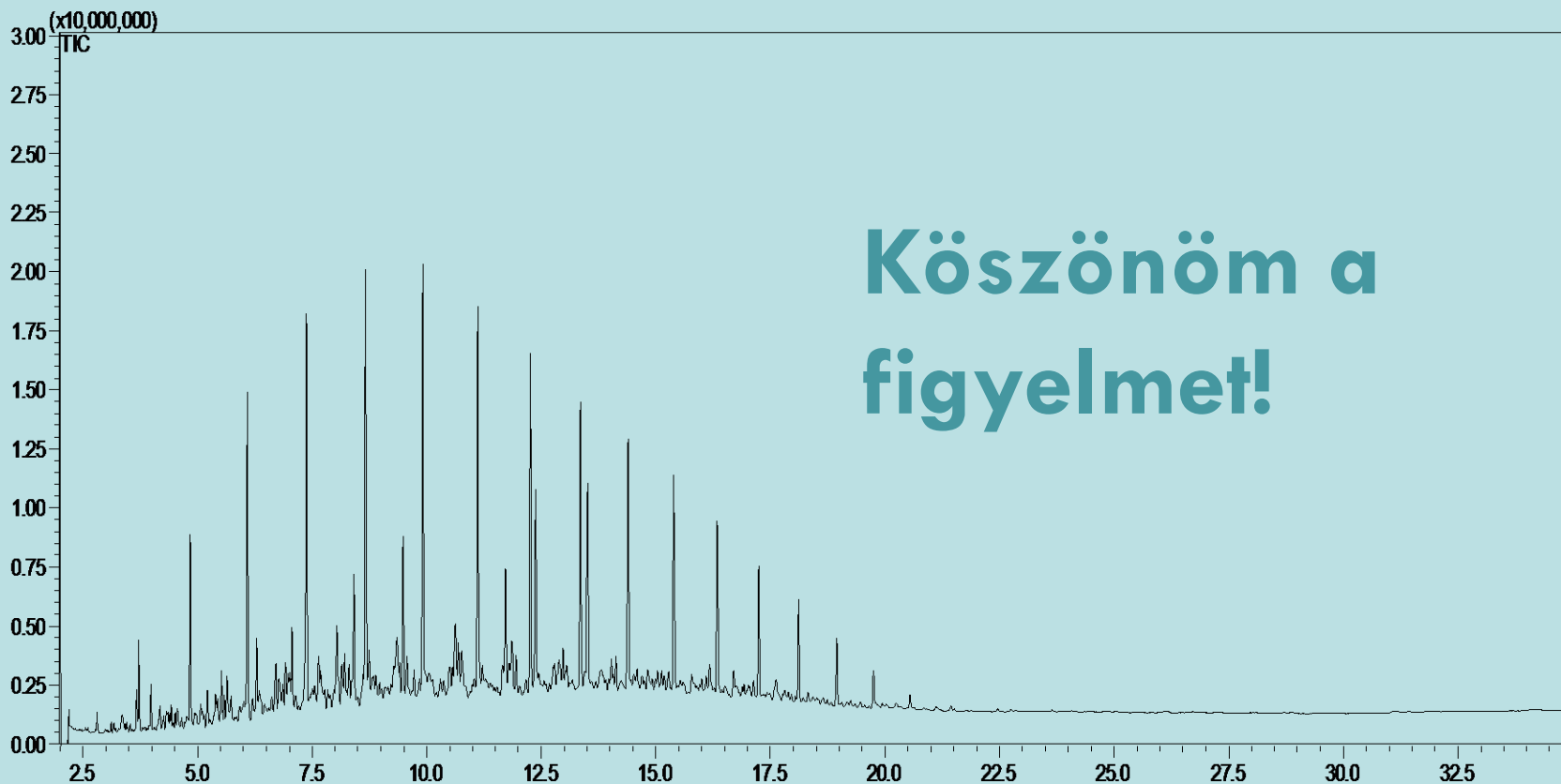

Irodalom:

- [1] A gázkromatográfia analitikai alkalmazásai, **2006**, Dr. Balla József
- [2] www.chromacademy.com
- [3] Gyakorlati tömegspektroszkópia, **1975**, Cornides István
- [4] www.shimadzu.com
- [5] Mass Spectrometry, **2017**, Jürgen H. Gross