

PROCESS CAPABILITY

Process Capability

Role of Quality Engineering

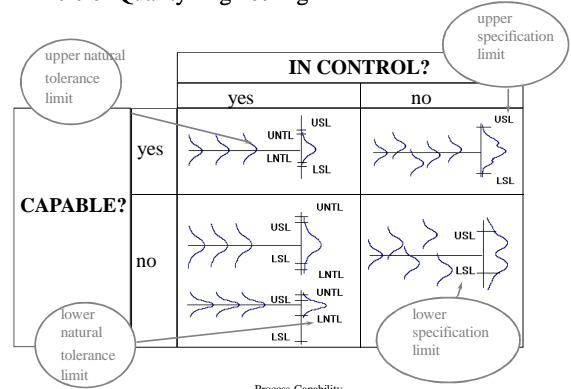

Process Capability

Analysis of process capability

Process capability index (Potential capability)

$$C_p = \frac{USL - LSL}{6\sigma}$$

Process Capability

Example 1

In a manufacturing process the expected value of a quality characteristic is 250.727 unit, the standard deviation is 1.286 unit. The specification is 250.5 unit. How much is the proportion of defectives in this process? Calculate the C_p capability index!

$$z_{upper} = \frac{USL - \mu}{\sigma} = P(x > USL) =$$

$$z_{lower} = \frac{LSL - \mu}{\sigma} = P(x < LSL) =$$

$$C_p = \frac{USL - LSL}{6\sigma}$$

Process Capability

$$C_p = \frac{USL - LSL}{6\sigma}$$

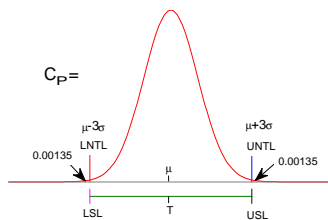

Process Capability

$$C_p = \frac{USL - LSL}{6\sigma}$$

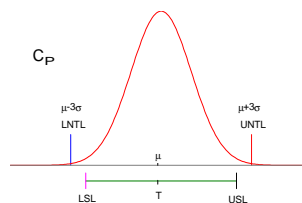

Process Capability

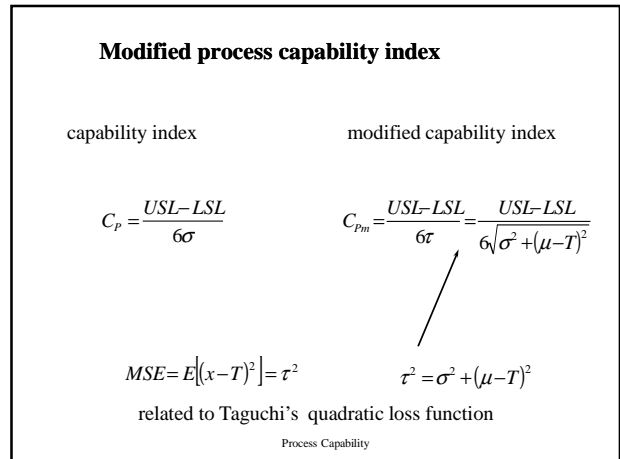
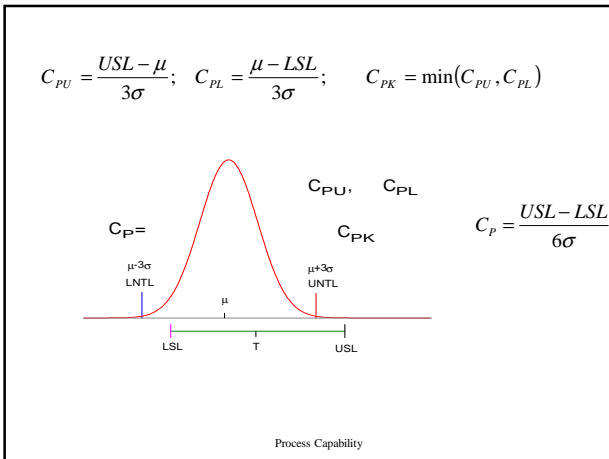
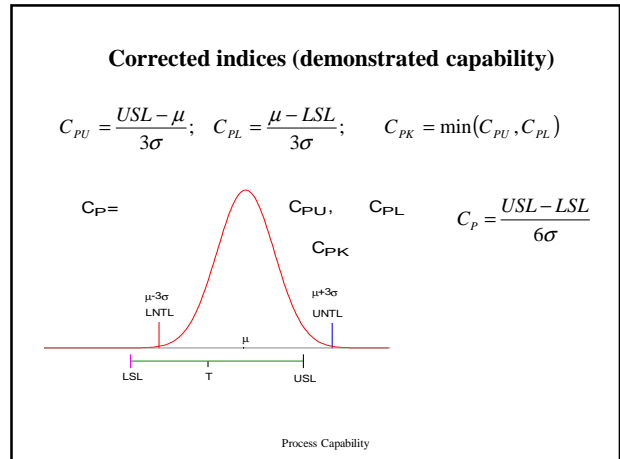
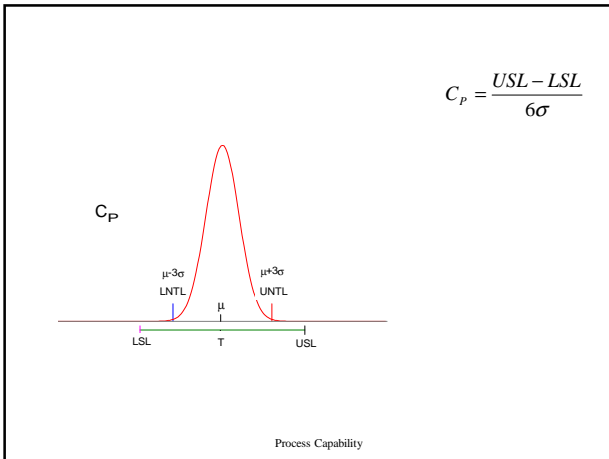

Example 2
 Compare two processes, the specification for both is 100 ± 1 .
 I. $s = 0.2, m = 99.5$, that is the center of fluctuation deviates from the nominal value
 II. $s = 0.4, m = 100$, that is the center of fluctuation is the nominal value, but the fluctuation is larger

Example 3
 The specification is $100 \pm 1, s = 0.2$. Calculate the capability indices and the proportion beyond specs (above USL or below LSL), if m is 100, 99.5 and 100.5!

Process Capability

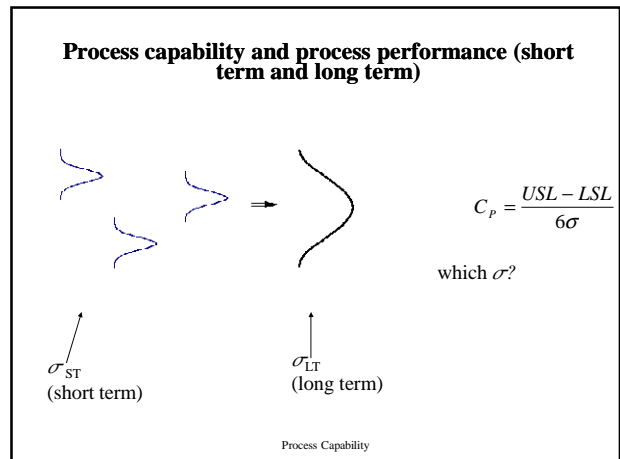

Estimating variance from the within-samples (short term) changes refers the internal, random fluctuation C_p (potential capability)

Combining both within-samples and between-samples changes the long term fluctuation is considered P_p (process performance)

$$P_p \leq C_p$$

Process Capability

The process capability study is to be interpreted for in-control processes only.

Two parts of the task:

1. Stabilize the process for an acceptable time span, eliminating potential sources of fluctuation (e.g. operator, lot of raw material)
2. Compare the long term process performance with that expected

How to check stability?

Process Capability